

150 Combination Coupling

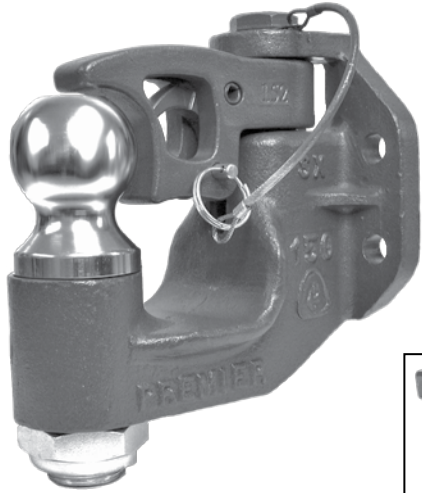

165 /166 Receiver (pg 69)

One of Premier's most unique and versatile couplings is our very popular model 150 Combination Coupling. Whether you need to pull a trailer with an eye or ball connection, the 150 can do the job. Our patented side-swinging latch helps prevent tailgate damage and keeps the profile compact.

ORDERING INFORMATION

Coupling and Ball Combinations:

- **150:** 150 coupling & 155 ball. MGTW: 10,000 lbs. (4,535 kg)
- **150-1:** 150 coupling & 156 ball. MGTW: 10,000 lbs. (4,535 kg)
- **150-2:** 150 coupling & 158 ball. MGTW: 2,500 lbs. (1,133 kg)

Optional Accessories:

- **Bolt Kit 159:** Four - 1/2 in. (13 mm) O.D. x 2 in. (51 mm) long bolts, lock washers and nuts.
- **Adjustable mounts for receiver-type connections (page 69):**
165 Receiver: 10,000 lbs. (4,535 kg) Max. gross trailer weight.
166 Receiver: 12,000 lbs. (5,443 kg) Max. gross trailer weight.
- **Replacement Balls (page 70):**
 155 Ball: 2 in. (51 mm) Diameter
 156 Ball: 2 5/16 in. (59 mm) Diameter
 158 Ball: 1 7/8 in. (48 mm) Diameter

SPECIFICATIONS

Max. Gross Trailer Weight with Eye:	16,000 lbs.	(7,257 kg)
Maximum Tongue Weight:	2,000 lbs.	(907 kg)
Ultimate Latch Capacity:	5,000 lbs.	(2,267 kg)
Maximum Eye X-Section:	1 13/16 in.	(46 mm)
Minimum Eye Opening:	2 3/8 in.	(60 mm)
Unit Weight:	14.4 lbs.	(6.5 kg)

DRAWING DETAIL

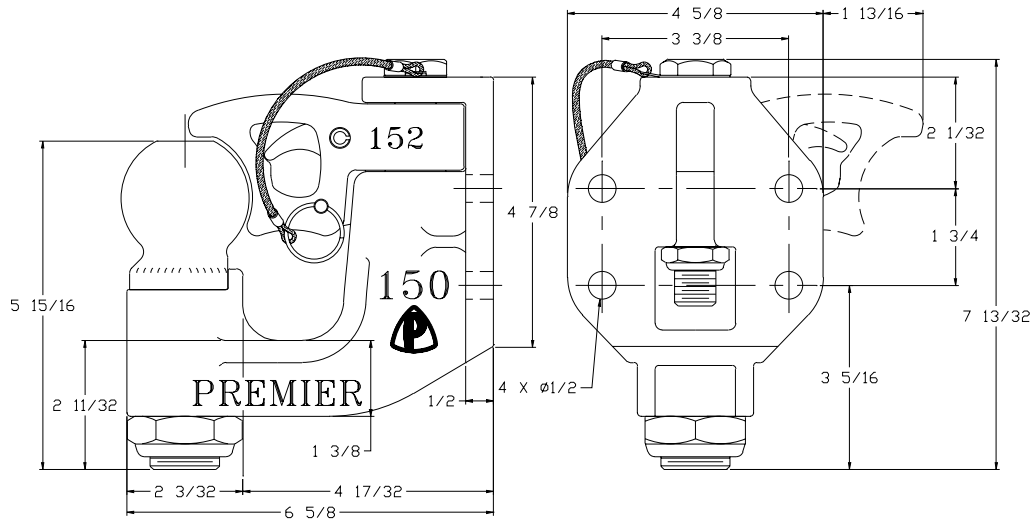

REPLACEMENT PART INFORMATION



155, 156, 158, with 157 Locknut

Model 150 Parts Available:

151: Trigger	155: Ball w/157 Locknut 2 in. (51 mm)
152: Latch	156: Ball w/157 Locknut 2 5/16 in. (59 mm)
152B: Bushing	158: Ball w/157 Locknut 1 7/8 in. (48 mm)
153A: Spring	
153B: Roll Pin	
154: Latch Pin	
274: Bolt	
274A: Locknut	

IMPORTANT GUIDELINES that apply to all Premier Non-Air Couplings

- Do not weld on any coupling assembly
- Always use Grade-8 fasteners properly torqued
- Do not apply lubricants to the coupling hook
- Clean & inspect coupling for damage & excessive wear prior to each and every use
- Lubricate all coupling components at a minimum of 90 day intervals
- Do not bind-up (Jackknife) any application as stresses can cause damage to products or components, resulting in failure and detachment of the trailer while in use

