

ORDERING INFORMATION

Coupling:

- 160

Optional Accessories:

- **Bolt Kit 159:** Four - 1/2 in. (13 mm) O.D. x 2 in. (51 mm) long bolts, lock washers and nuts.
- **Adjustable mounts for receiver-type connections (page 69):**
165 Receiver: 10,000 lbs. (4,535 kg) Max. gross trailer weight.
166 Receiver: 12,000 lbs. (5,443 kg) Max. gross trailer weight.



165 / 166 Receiver (pg 69)

The same unique latching as our model 150 (page 28), the model 160 offers a compact profile for tight places. Ideal for dolly haul back and other light to medium duty applications.

SPECIFICATIONS

Maximum Gross Trailer Weight:	30,000 lbs.	(13,607 kg)
Maximum Tongue Weight:	4,500 lbs.	(2,041 kg)
Ultimate Latch Capacity:	5,000 lbs.	(2,267 kg)
Maximum Eye X-Section:	1 13/16 in.	(46 mm)
Minimum Eye Opening:	2 in.	(51 mm)
Unit Weight:	12.6 lbs.	(5.7 kg)

DRAWING DETAIL

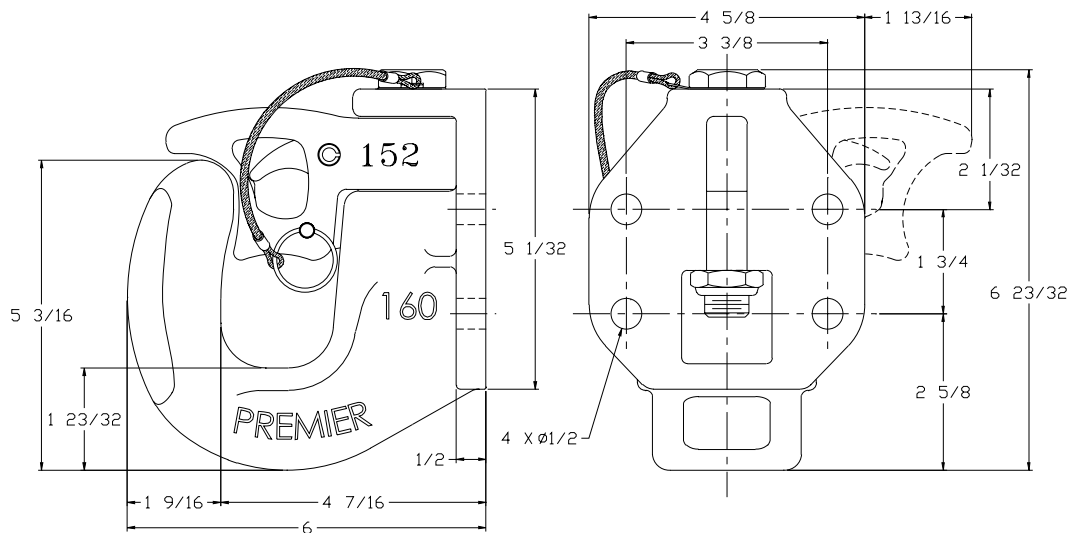

REPLACEMENT PART INFORMATION

Model 160 Parts Available:

- 151: Trigger
- 152: Latch
- 152B: Bushing
- 153A: Spring
- 153B: Roll Pin
- 154: Latch Pin
- 274: Bolt
- 274A: Locknut



IMPORTANT GUIDELINES that apply to all Premier Non-Air Couplings

- Do not weld on any coupling assembly
- Always use Grade-8 fasteners properly torqued
- Do not apply lubricants to the coupling hook
- Clean & inspect coupling for damage & excessive wear prior to each and every use
- Lubricate all coupling components at a minimum of 90 day intervals
- Do not bind-up (Jackknife) any application as stresses can cause damage to products or components, resulting in failure and detachment of the trailer while in use

