

890CL / 890CR Drop-Pintle Coupling

ORDERING INFORMATION

Coupling:

- 890CL / 890CR

Optional Accessories:

- Bolt Kit 507: Four - 3/4 in. (19 mm) O.D. x 2 3/4 in. (70 mm) long bolts, and nuts
- Wear Gage 14014 (page 66): To determine hook wear limits.
- Latch Gage 14026 (page 66): To determine latch gap limit.

Can be quickly and easily converted to left or right-hand operation.



*Hook Only



890CR

Similar to the 890 (page 40), Premier's 890C offers a slightly different mounting pattern for compatibility with existing x-members. **NOT to be used for A-Dolly applications.**

SPECIFICATIONS

Maximum Gross Trailer Weight:	90,000 lbs.	(40,823 kg)
Maximum Tongue Weight:	18,000 lbs.	(8,164 kg)
Upward Vertical Capacity:	18,000 lbs.	(8,164 kg)
Maximum Eye X-Section:	1 13/16 in.	(46 mm)
Minimum Eye Opening:	2 3/8 in.	(60 mm)
Unit Weight:	58.8 lbs.	(26.7 kg)

DRAWING DETAIL

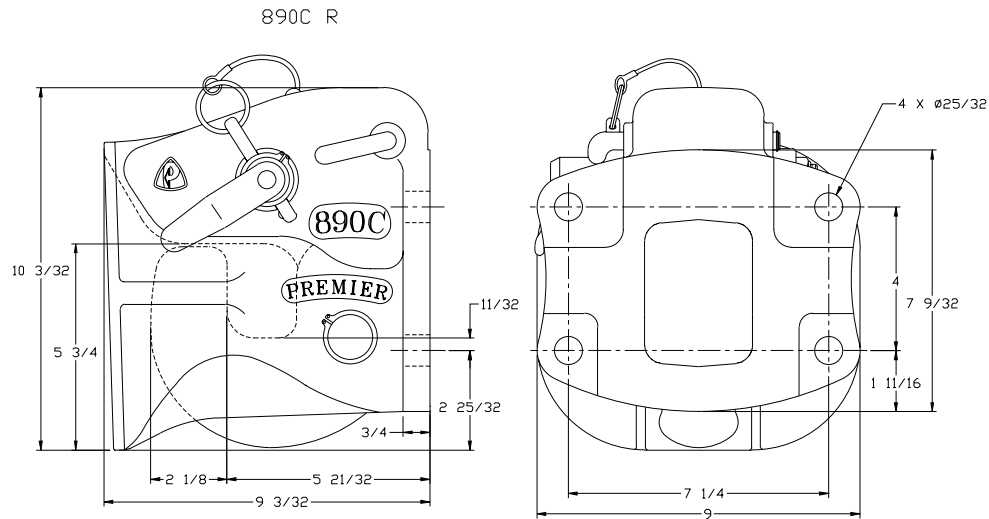

REPLACEMENT PART INFORMATION

Model 890C Parts Available:

891: Handle	895A: Spring
891C: Bushing	275-50: Snap Ring
891P: Pin & Cable	895C: Set Screw
892: Hook	896: Handle
893: Pawl	387: Locknut
893A: Spring	16DS: Drive Screw
894: Pin	
894Z-1: Snap Ring (3)	
895: Latch	

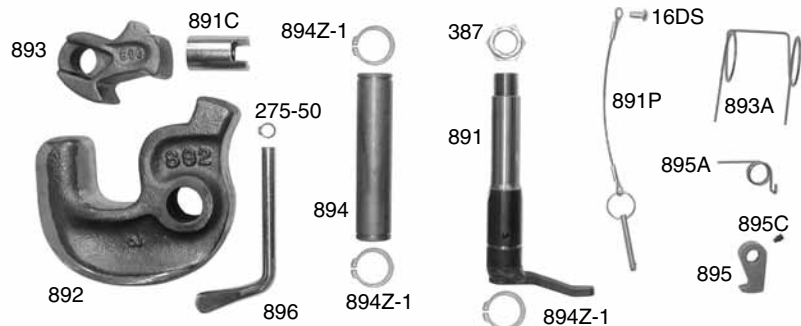

IMPORTANT GUIDELINES that apply to all Premier Non-Air Couplings

- Do not weld on any coupling assembly
- Always use Grade-8 fasteners properly torqued
- Do not apply lubricants to the coupling hook
- Clean & inspect coupling for damage & excessive wear prior to each and every use
- Lubricate all coupling components at a minimum of 90 day intervals
- Do not bind-up (Jackknife) any application as stresses can cause damage to products or components, resulting in failure and detachment of the trailer while in use

