

Weld-On Drawbar Eyes

11 Weld-On Eye



SPECIFICATIONS

Maximum Gross Trailer Weight:	70,000 lbs.	(31,751 kg)
Maximum Tongue Weight:	10,500 lbs.	(4,762 kg)
Inside Diameter:	2 3/8 in.	(60 mm)
Unit Weight:	7.7 lbs.	(3.5 kg)

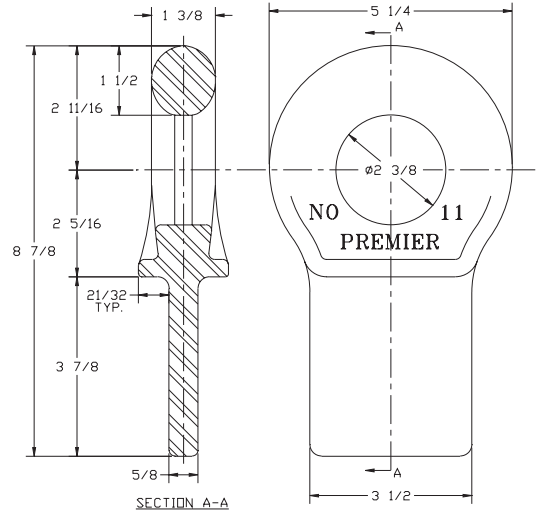

304 Weld-On Eye



SPECIFICATIONS

Maximum Gross Trailer Weight:	150,000 lbs.	(68,038 kg)
Maximum Tongue Weight:	15,000 lbs.	(6,803 kg)
Inside Diameter:	3 in.	(76 mm)
Unit Weight:	13.3 lbs.	(6.0 kg)

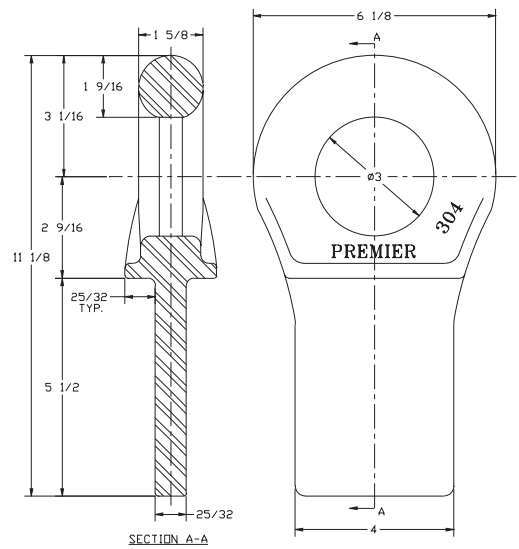

306 Weld-On Eye



SPECIFICATIONS

Maximum Gross Trailer Weight:	150,000 lbs.	(68,038 kg)
Maximum Tongue Weight:	15,000 lbs.	(6,803 kg)
Inside Diameter:	3 in.	(76 mm)
Unit Weight:	16.5 lbs.	(7.5 kg)

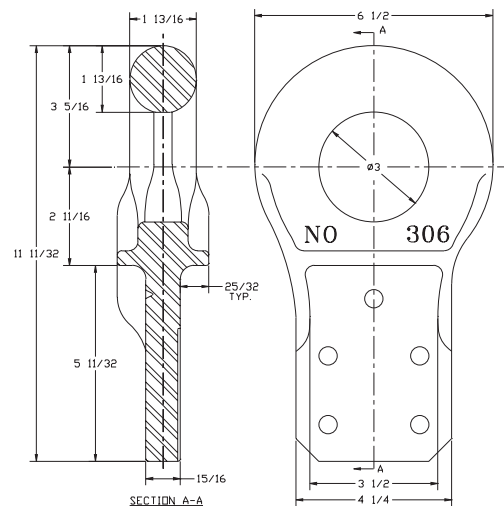

IMPORTANT GUIDELINES that apply to all Premier Weld-On Drawbar Eyes

- Never attempt weld repair of damaged or worn drawbar eyes
- Air adjusted drawbar eyes must be used with an air service chamber or #500 slack adjuster
- Clean and inspect drawbar eyes and eye assemblies for damage or excessive wear before each and every use
- Do not apply lubricants to the drawbar eye loop
- Structure to which eye is attached must be of sufficient strength to withstand load rating of eye
- All welds for attaching eye should be done by a certified welder skilled in structural welding
- Do not bind-up (Jackknife) any application as stresses can cause damage to products or components, resulting in failure and detachment of the trailer while in use