

# Hinge Assemblies

## 320 / 320A Hinge Assembly

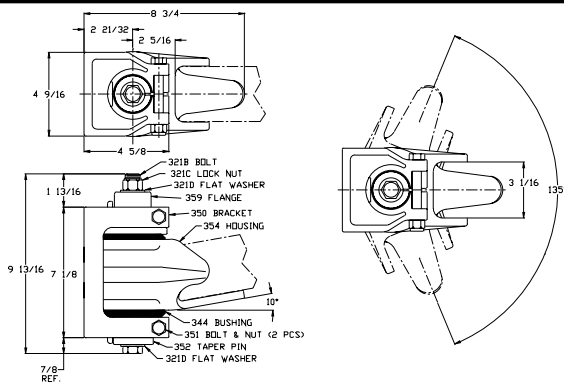

Accepts 3 in. (76 mm) standard channel or square tubing.

344 Rubber Bushings standard, 344A Poly optional (320A)



### SPECIFICATIONS



**Bushing Replacement:** 344 (Rubber) or 344A (Poly)  
**Outside Diameter:** 3 1/2 in. (89 mm)  
**Length:** 4 1/2 in. (114 mm)

**Max. Gross Trailer Weight (pair):** 100,000 lbs. (45,359 kg)  
**Unit Weight (pair):** 50.2 lbs. (22.8 kg)

## 330 / 330A Hinge Assembly

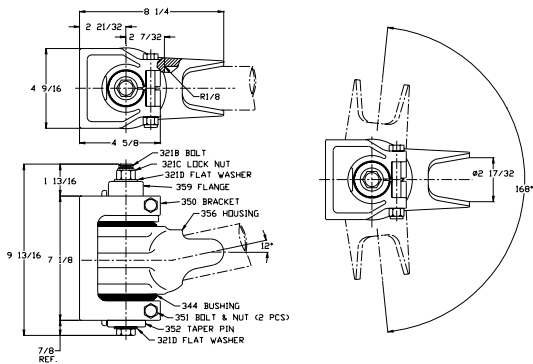

Accepts 2 1/2 in. (64 mm) round tubing.

344 Rubber Bushings standard, 344A Poly optional (330A)



### SPECIFICATIONS



**Bushing Replacement:** 344 (Rubber) or 344A (Poly)  
**Outside Diameter:** 3 1/2 in. (89 mm)  
**Length:** 4 1/2 in. (114 mm)

**Max. Gross Trailer Weight (pair):** 100,000 lbs. (45,359 kg)  
**Unit Weight (pair):** 50.2 lbs. (22.8 kg)

## 430 / 430A Hinge Assembly

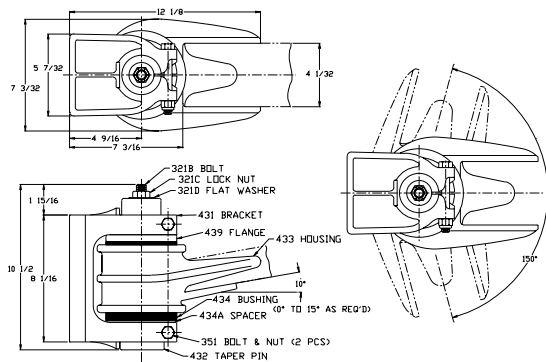

Accepts 2 in. x 4 in. (51 mm x 102 mm) rectangular tubing or channel.

434 Rubber Bushings standard, 434B Poly optional (430A)

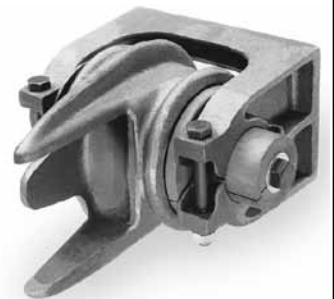

### SPECIFICATIONS



**Bushing Replacement:** 434 (Rubber) or 434B (Poly)  
**Outside Diameter:** 4 1/4 in. (108 mm)  
**Length:** 5 in. (127 mm)

**Max. Gross Trailer Weight (pair):** 150,000 lbs. (68,038 kg)  
**Unit Weight (pair):** 86 lbs. (39.0 kg)

### IMPORTANT GUIDELINES that apply to all Premier Hinge Assemblies

- Never attempt weld repair of damaged or worn hinge components
- Clean and inspect hinge assemblies for damage or excessive wear before each and every use
- All weld attachments should be performed by a certified welder skilled in structural welding

- The mounting structure the hinges are welded to must be of sufficient strength to withstand load ratings of hinges
- Do not bind-up (Jackknife) any application as stresses can cause damage to products or components, resulting in failure and detachment of the trailer while in use

