



PREMIER

THE FIRST NAME IN QUALITY COUPLINGS

294 Bolt Replacement Procedure for 690 Coupling

! WARNING !

All 294 bolts are considered a serviceable part & cannot surpass 1-year of use. After 1-year of vehicle installation, it is considered out-of-service and no longer usable.

294 Bolt Service Life Instructions

The following applies to all Premier Model 690 couplings (690L, 690R, 690T)

For new 690 coupling or new/replaced 294 bolt:
Record the date of installation.

6-months after installation date:

Remove & inspect entire 294 bolt and look for fractures along entire length of bolt (preferably using dye penetrant or mag particle testing).

- If 294 bolt looks good: Re-install & continue to use for another 6-months.
- If fractured DO NOT USE: Contact Premier Mfg Co.

1-year after installation date (regardless of service duty):

Remove & replace with new 294 bolt.

WARNING: If, at any time, the 690 Coupling is bound-up (jackknifed), then the 294 Bolt MUST be replaced immediately! Until replacement, the 690 Coupling is not to be used. Furthermore, carefully inspect the 690 Coupling; drawbar; drawbar eye; front end assembly; and tail board for damage.

NOTE: Before performing the 294 Bolt replacement procedure, first verify that your 690 Coupling is not in need of a complete repair kit. With the 690 Coupling in the closed position, pull outward on the 692 Pintle. The measured gap between the top of the 692 Pintle and the adjacent face of the 690 Coupling Body must be less than 3/8". At 3/8" or greater, the coupling is no longer suitable for service. A repair kit will be necessary to return the coupling to service. The other option is to install a new 690 Coupling.

294 BOLT REPLACEMENT PROCEDURE:

- 1) Place the 690 Coupling in the OPEN position as shown in the Left Side View in Figure 1.
- 2) Remove the *295Z-87 Snap Ring from the end of the 294 Bolt and discard. *Only found on old style 294 Bolt.
- 3) Remove the 297 Locknut from the 294 Bolt and discard.
- 4) While gripping the 692 Pintle, slide the 294 Bolt out of the 690 Coupling Body.

- 5) Destroy (by hammer or file) the threaded end of the 294 Bolt and discard.
- 6) Thoroughly clean the 690 Coupling Body holes where the 294 Bolt resided, as well as the interior surfaces of the 690 Coupling Body. Clean the hole as well as all surfaces of the 692 Pintle.
- 7) Measure the hole diameter on each side of the coupling body, which the 294 Bolt resided in. If the diameter exceeds 1.156, then the coupling body is to be considered out of service and must be replaced.
- 8) Carefully inspect the upper (691 Handle) body hole for wear. A gap between the 691 Handle shaft and hole circumference of 1/32" or greater indicates that the handle assembly needs to be removed and body holes measured for wear. After handle removal, measure both hole diameters. If either hole diameter exceeds 1.300, the coupling is to be considered out-of-service and must be replaced.
- 9) After cleaning, test fit the 294 Bolt by placing the new 294 Bolt through the 690 Coupling Body, without the 692 Pintle, from the right side. Make certain the new 294 Bolt head is flush with the outer 690 Coupling Body side wall.
 - If the new 294 Bolt head and 690 Coupling Body are not flush, two possible causes are shown in Figures 2A & 2B.
 - Figure 2A shows a gap between the new 294 Bolt head and the 690 Coupling Body caused by a sharp and/or unchamfered hole in the 690 Coupling Body. This can be resolved by grinding a 45° chamfer, no larger than 1/16," around the entire circumference of the 690 Coupling Body hole.
 - Figure 2B demonstrates the new 294 Bolt not being flush due to the 690 Coupling Body bolt stop. This can be rectified by grinding or filing the bolt stop for adequate clearance.
- 10) The 690 Coupling is now ready for final assembly.
- 11) Remove the 294 Bolt and apply heavy grease to the 692 Pintle hole, 690 Coupling Body holes as well as the shank of the new 294 bolt (Do NOT lubricate the threads).
- 12) Place the 692 Pintle into the 690 Coupling Body, aligning the pintle hole with the body holes. Insert the new 294 Bolt through the aligned holes from the right side. Thoroughly remove any lubrication from threads of 294 Bolt.
- 13) One of the four flats on the head of the new 294 Bolt must be adjacent to the bolt head stop on the 690 Coupling Body as shown in the Right Side View in Figure 1. (Note: It is fine if the bolt stop does not prevent the new 294 Bolt from rotating.)

(Instructions continued on next page)



- 14) Grasp the new 294 Bolt head with a wrench and thread a new 297 Locknut onto the 294 Bolt. Again, first make certain that no lubricant is present on the 294 Bolt threads. Torque to 50 ft-lbs.
- 15) Open and close the 690 Coupling several times, making sure it operates smoothly and correctly.

WARNING:

- ▶ Do NOT bind-up (jackknife) any application, as stresses can cause damage to the 294 bolt, hitch, drawbar eye, other components or any combination of them. Jackknifing may result in failure of products or components, resulting in detachment of the trailer while in use.

ATTENTION !

End Users must read and follow this information.

DISTRIBUTORS & OEM'S: Please ensure that your customers are made aware of the following information on this page.

- (1) **VERIFY THAT BOTH COUPLING'S AND DRAWBAR EYE'S RATED CAPACITIES MEET YOUR APPLICATION(S) REQUIREMENTS.**
- (2) DO NOT OVERLOAD HITCH OR DRAWBAR EYE.
- (3) INSPECT HITCH, LATCH AND DRAWBAR EYE FOR CRACKS, BENDING DAMAGE OR EXCESSIVE WEAR. **DO NOT USE IF ANY OF THESE CONDITIONS EXIST!**
- (4) CHECK FOR GAP BETWEEN CLOSED LATCH AND TOP OF HORN OR HITCH BALL. **DO NOT USE IF GAP IS 3/8 IN. OR MORE.**
- (5) MAKE SURE HITCH IS LATCHED AND THAT LATCH WILL NOT OPEN.
- (6) PRIOR TO USE, ALWAYS CONNECT SAFETY CHAINS OF ADEQUATE STRENGTH FOR LOAD(S) BEING TOWED.
- (7) DO NOT BIND-UP (JACKKNIFE) ANY APPLICATION AS STRESSES CAN CAUSE DAMAGE TO THE HITCH, DRAWBAR EYE, OTHER COMPONENTS OR ANY COMBINATION OF THEM. JACKKNIFING MAY RESULT IN FAILURE OF PRODUCTS OR COMPONENTS, RESULTING IN DETACHMENT OF THE TRAILER WHILE IN USE.

- (8) DO NOT APPLY LUBRICANTS TO THE COUPLING HOOK OR DRAWBAR EYE LOOP, AS THEY CAN COVER UP POSSIBLE DAMAGE AND ACCELERATE WEAR.
- (9) ALWAYS ABIDE BY ALL APPLICABLE STATE AND FEDERAL REGULATIONS GOVERNING SAFE AND PROPER TRANSPORTATION.
- (10) NEVER STRIKE ANY OF THESE COMPONENTS WITH A HAMMER OR ANY OTHER DEVICE.
- (11) ALWAYS VERIFY PROPER OPERATION OF LATCHING SYSTEM AND COUPLING COMPONENTS PRIOR TO DRIVE OFF.
- (12) NEVER USE A HITCH THAT YOU DO NOT FULLY UNDERSTAND HOW TO PROPERLY OPERATE AND VERIFY SECURE LATCHING OF.
- (13) **NEVER REPLACE ANY PART IN ANY OF PREMIER'S ASSEMBLIES WITH NON-PREMIER COMPONENTS. DOING SO WILL VOID ALL WARRANTY AND POTENTIALLY COMPROMISE THE UNIT'S INTEGRITY, WHICH COULD RESULT IN PROPERTY DAMAGE, SERIOUS INJURY, OR DEATH.**



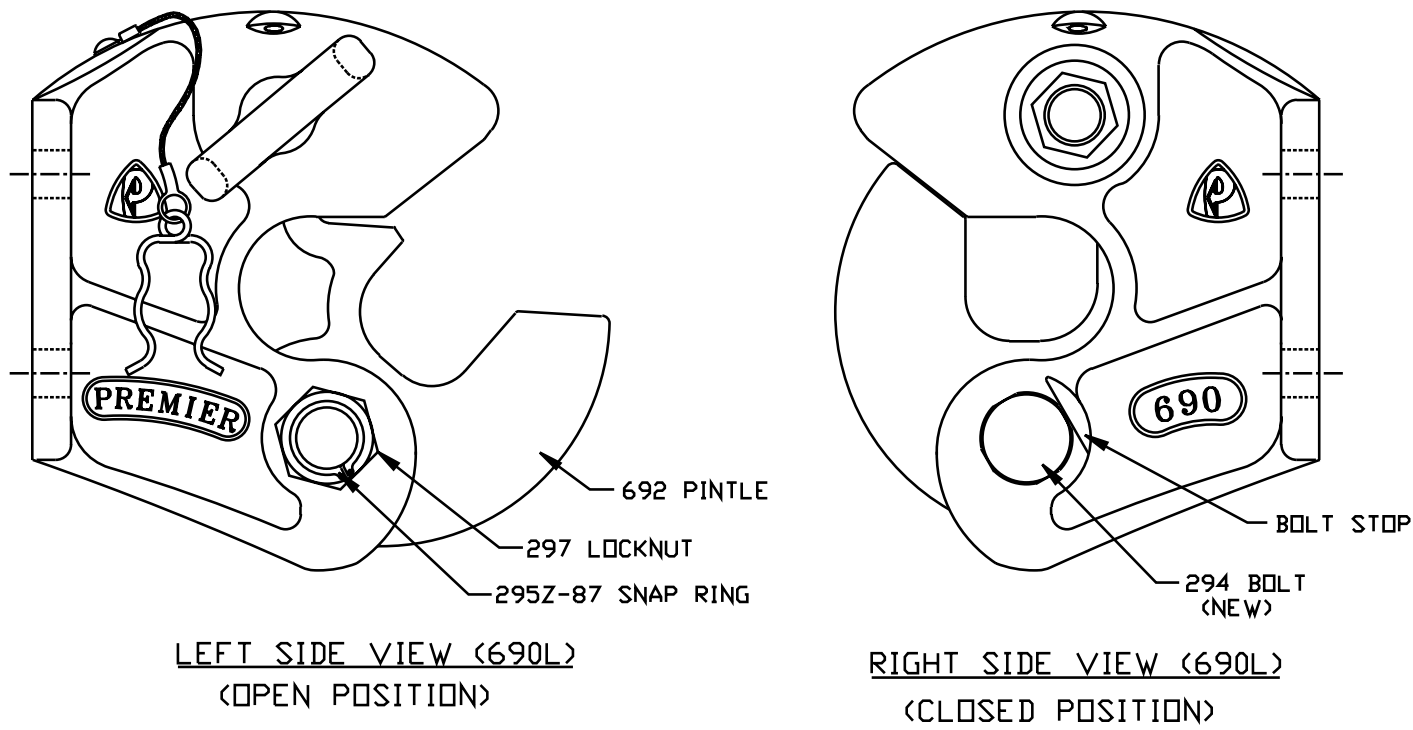

FIGURE 1

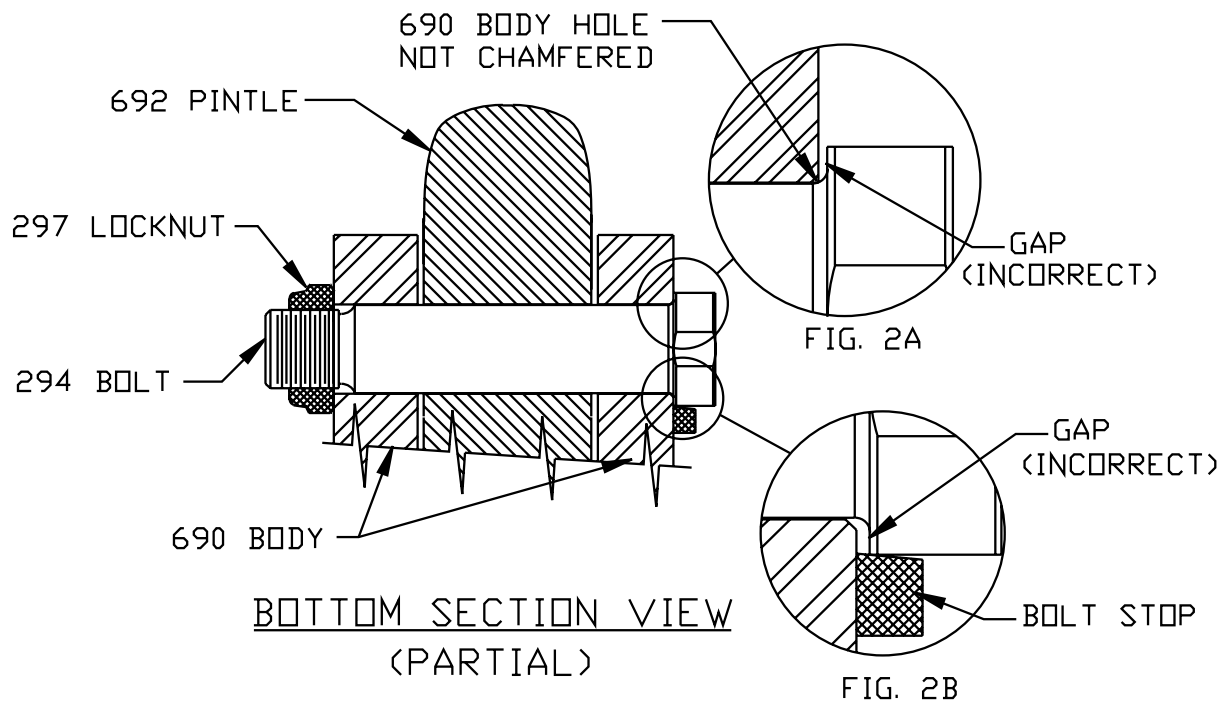

FIGURE 2



WARNING!

Important Installation Instructions:

Do NOT attempt install without first reading all attached instructions.

Installation must be performed by a qualified mechanic only.

294 Bolt Replacement for Models 690
Revised 04/01/09

WARRANTY: We warrant all Premier products to be free from defects in material or workmanship for one year. We will repair or replace, at our option, any Premier product which our examination reveals to be defective, provided that the product is returned to our factory, at Tualatin, Oregon transportation prepaid, within one year of purchase by the first retail purchaser. Our warranty does not extend to products which have been subject to misuse, neglect, improper installation, maintenance or application, nor does our warranty extend to products which have been repaired or altered outside of Premier's facility unless the repair or alteration has been expressly authorized in writing by Premier. ***This warranty is in lieu of all other warranties, express or implied, and excludes warranties of merchantability, fitness for a particular purpose and otherwise, and in no event will Premier be liable for incidental, special, contingent or consequential damages.***

DISCLAIMER: Although great care has been taken to ensure accurate information throughout this catalog, Premier Manufacturing Company must reserve the right to alter any information contained within. These changes include but are not limited to: Dimensional changes, in load capacity and availability of any part or assembly.

© 2009 Premier Manufacturing Company

All rights reserved. Any reproduction of the photographic images or any other portion of this catalog, including but not limited to the photocopying, or retention and/or storage in a retrieval system of any kind, is strictly prohibited without prior express written permission from Premier Manufacturing Company.

