

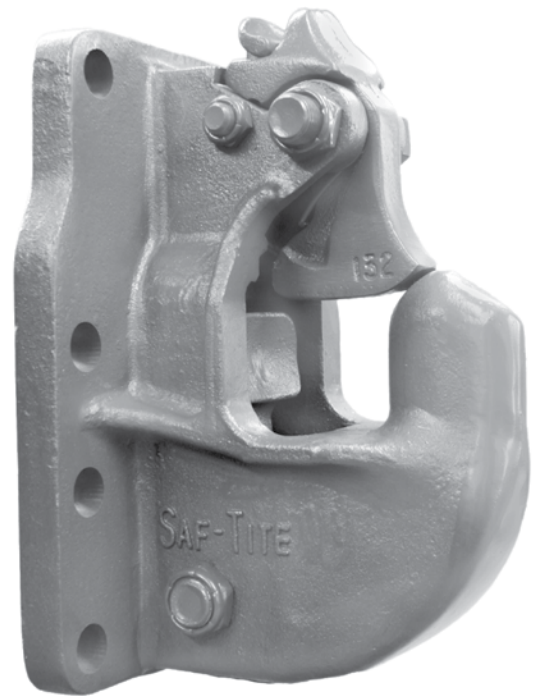

PREMIER MANUFACTURING CO.

THE FIRST NAME IN QUALITY COUPLINGS

Installation, Inspection, Operation & Maintenance Guide

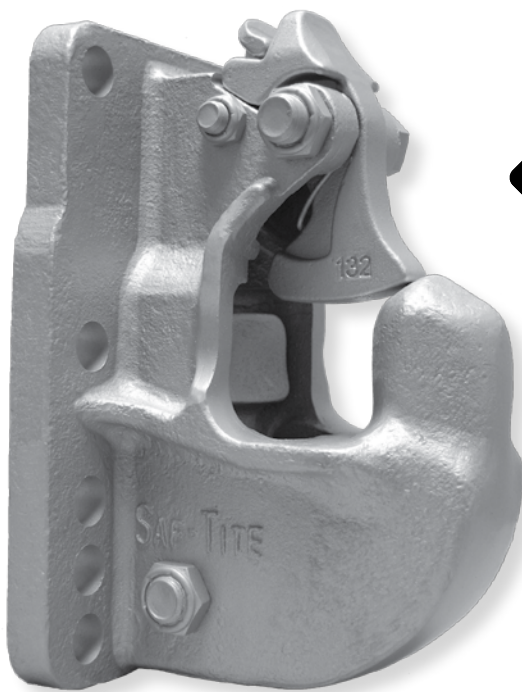

Saf-Tite 100-4 / 100-4H Coupling

IMPORTANT

Read these instructions completely before installing, using or attempting to repair this product. If you have any questions, call Premier at (800) 255-5387 or (503) 234-9202.

Selecting The Right Equipment

Whatever your application, selecting the proper equipment for the job is very important. Proper selection along with regular inspection and maintenance will help keep operating costs minimal while providing long life to each component. Below are general guidelines for selecting Premier Couplings and Drawbar Eyes. If you feel that your application is unique, please give Premier a call so that we may help you through the selection process.

Follow these four steps to ensure proper selection of Premier Couplings and Drawbar Eyes.

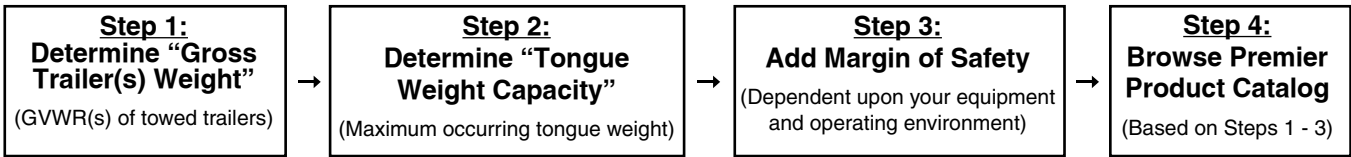

Step 1: Determine "Gross Trailer(s) Weight"

"Gross Trailer(s) Weight" is usually determined by the Gross Vehicle Weight Rating (GVWR). This information is attached to the trailer by the trailer manufacturer.

Double Trailer Configuration



Example only, each application may vary and should be considered unique.

For "Double Trailer" configurations, only the rear trailer is considered when selecting your Premier Coupling or Drawbar Eye. In this example, a Coupling and Drawbar Eye with a "Gross Trailer Weight" rating of 40,000 lbs. (18,143 kg) would be the minimum rating acceptable for normal, over-the-road applications (see Tongue Weight section below).

Triple Trailer Configuration



Example only, each application may vary and should be considered unique.

For "Triple Trailers", only the two most rearward trailers are considered in selecting your Premier Coupling or Drawbar Eye. In this example, a Coupling and Drawbar Eye with a "Gross Trailer Weight" rating of 80,000 lbs. (36,287 kg) would be the minimum acceptable for normal, over-the-road applications (see Tongue Weight section below).

Step 2: Determine "Tongue Weight Capacity"



"Tongue Weight Capacity" is the maximum expected weight at the drawbar eye. If a hinged drawbar is used, the maximum weight will be approximately 1/2 the overall drawbar weight. If a non-hinged drawbar is used and the actual tongue weight is not known, you can approximate the weight by multiplying the GVWR of the towed trailer by 15%. However, each application is unique and the best practice is to weigh the tongue when the trailer is loaded to its GVWR.

Step 3: Considering Operating Conditions and Environments

Environments such as rough uneven roads or off-road use can dramatically increase shock loads to both drawbar eyes and couplings. In general, increasing the "Gross Trailer Weight" (Step 1:) and "Tongue Weight Capacity" (Step 2:) by a minimum of 25% will be sufficient for many applications. Even if an application is used off-road occasionally, the minimum increase necessary for Gross Trailer and Tongue Weight is 25%. Certain types of equipment and/or operating practices can also dramatically increase loads through equipment binding and/or improper loading practices. Of special concern is high tongue weight. However, each application is unique and every environment different, therefore your application may require more than 25%.

Once both "Gross Trailers(s) Weight" (Step 1:) and "Tongue Weight Capacity" (Step 2:) have been determined, evaluate your operating conditions and apply an appropriate margin of safety.

Step 4: Browse Premier Product Catalog

Browse the Premier Product Catalog and refer to the "Specifications" section of each product. Be sure to review the "Understanding Premier Load Specifications" section and "Coupling to Drawbar Eye Cross-Reference" sheet on the next couple pages.



Selecting The Right Equipment

Understanding Premier Load Specifications

Each Premier product undergoes extensive design and testing prior to being introduced. We use the latest in Computer Aided Design and Analysis Software as well as physical destructive tests. Premier's published load specifications are the maximum load a given product or part will withstand without failure. Premier's testing procedures closely follow the Society of Automotive Engineers (SAE) guidelines of Recommended Practice for testing Couplings and Drawbar Eyes (SAE J847 & J849).

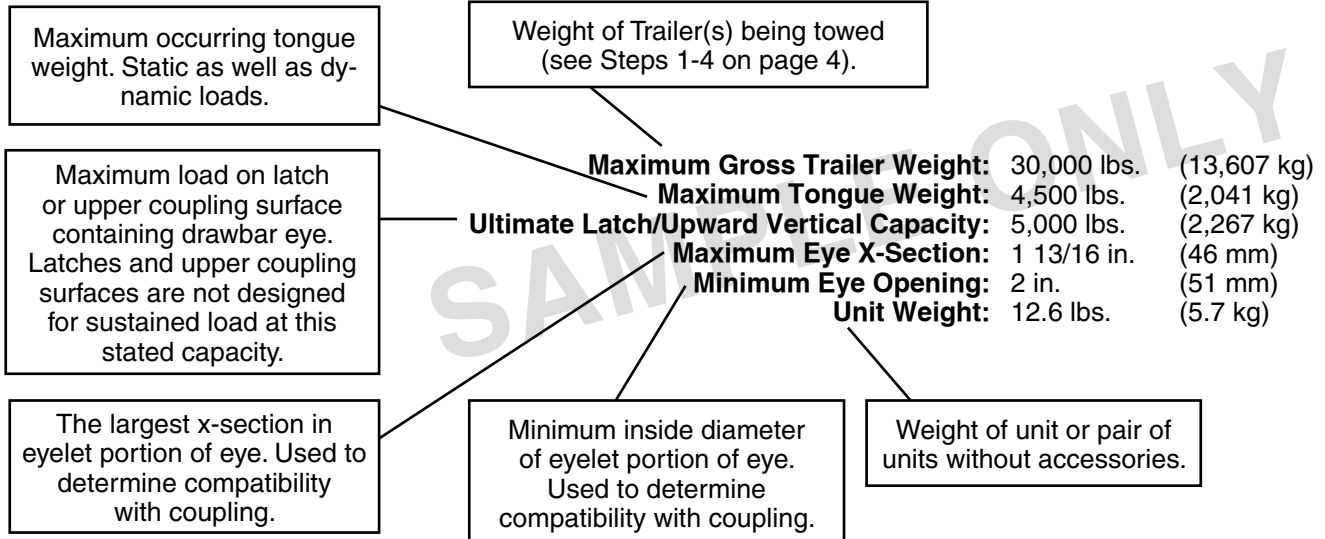

Importance of Inspection and Maintenance

Safety is our #1 Priority: Through high quality designs and unsurpassed quality control procedures, Premier assures our customers that our focus on safety continues to be our #1 priority.

Scheduled Inspection & Maintenance: Regularly scheduled inspection and maintenance are essential for maintaining safe and efficient operations whether you are using Couplings, Drawbar Eyes, Jacks, Hinge Assemblies, or any other Premier product. Inspection and maintenance are necessary for proper function and will also keep repair costs to a minimum.

Technical Literature: Premier provides important literature to assist you with our products. We package and attach *Installation, Inspection, Operation & Maintenance Guides*, or *Service Guides*, to each of our major products. This literature is also available to view and/or print from our website at www.premier-mfg.com. These supply you with important information and help guide you through installation, inspection, operation, routine maintenance and part replacement.

Wear Gages: In accordance with the Federal Motor Carrier Safety Regulations, we created Wear Gages to assist you in determining the wear limits of Premier couplings and drawbar eyes. See details on catalog pages 7 & 75.

Additional Product Resources at Your Fingertips

Customer Service: We are always here to support you. Do you need additional information or assistance? Your phone calls are greeted by our courteous receptionist, during business hours. We have exceptional, personable Customer Service Reps for you to rely on. If you have product questions or want to place an order, you can speak directly with one of our experienced and knowledgeable Customer Service Representatives.

Sales Representatives: Would you like on site training or assistance? Contact one of our veteran Premier Sales Reps for more information about product training for your staff. Or be sure to visit with them at a Trade Show (see website for schedule).

www.premier-mfg.com: Our website is an informative resource at your fingertips. In addition to our Installation and Service Guides, you will find our Sales Representatives, distributor locations, online catalog pages, product specifications, how to select product, trade show schedule, and links to trucking resources.



Selecting The Right Equipment

Coupling - to - Drawbar Eye, Cross Reference Chart

Couplings	Drawbar Eyes																																			
	2*	3	4	5	6/6A	8	11	20	21	22	23	107	108	110	123	125	126	127	200	200L	203	205	207	238DB	245DB	245DB-3	300	304	305	306	307	309	405	407SE	410	
16	•	•	•	•	•	•	•	•	•	•	•	•	•	•	•	•	•	•	•	•	•	•	•	•	•	•	•	•	•	•	•	•	•	•	•	•
24	•																																			
40	•																																			
100 †			•	•	•	•	•	•	•	•	•	•	•	•	•	•	•	•	•	•	•	•	•	•	•	•	•	•	•	•	•	•	•	•	•	•
100-3 †			•	•	•	•	•	•	•	•	•	•	•	•	•	•	•	•	•	•	•	•	•	•	•	•	•	•	•	•	•	•	•	•	•	•
100-4 †			•	•	•	•	•	•	•	•	•	•	•	•	•	•	•	•	•	•	•	•	•	•	•	•	•	•	•	•	•	•	•	•	•	•
100-4H †			•	•	•	•	•	•	•	•	•	•	•	•	•	•	•	•	•	•	•	•	•	•	•	•	•	•	•	•	•	•	•	•	•	•
130	•	•	•	•	•	•	•	•	•	•	•	•	•	•	•	•	•	•	•	•	•	•	•	•	•	•	•	•	•	•	•	•	•	•	•	•
135NT		•	•	•	•	•	•	•	•	•	•	•	•	•	•	•	•	•	•	•	•	•	•	•	•	•	•	•	•	•	•	•	•	•	•	•
140	•	•				•																														
150			•	•	•	•	•	•	•	•	•	•	•	•	•	•	•	•	•	•	•	•	•	•	•	•	•	•	•	•	•	•	•	•	•	•
160	•	•	•	•	•	•	•	•	•	•	•	•	•	•	•	•	•	•	•	•	•	•	•	•	•	•	•	•	•	•	•	•	•	•	•	•
235NT			•	•	•	•	•	•	•	•	•	•	•	•	•	•	•	•	•	•	•	•	•	•	•	•	•	•	•	•	•	•	•	•	•	•
240		•	•	•	•	•	•	•	•	•	•	•	•	•	•	•	•	•	•	•	•	•	•	•	•	•	•	•	•	•	•	•	•	•	•	•
240K			•	•	•	•	•	•	•	•	•	•	•	•	•	•	•	•	•	•	•	•	•	•	•	•	•	•	•	•	•	•	•	•	•	•
270			•	•	•	•	•	•	•	•	•	•	•	•	•	•	•	•	•	•	•	•	•	•	•	•	•	•	•	•	•	•	•	•	•	•
290			•	•	•	•	•	•	•	•	•	•	•	•	•	•	•	•	•	•	•	•	•	•	•	•	•	•	•	•	•	•	•	•	•	•
360			•	•	•	•	•	•	•	•	•	•	•	•	•	•	•	•	•	•	•	•	•	•	•	•	•	•	•	•	•	•	•	•	•	•
370			•	•	•	•	•	•	•	•	•	•	•	•	•	•	•	•	•	•	•	•	•	•	•	•	•	•	•	•	•	•	•	•	•	•
370B			•	•	•	•	•	•	•	•	•	•	•	•	•	•	•	•	•	•	•	•	•	•	•	•	•	•	•	•	•	•	•	•	•	•
470			•	•	•	•	•	•	•	•	•	•	•	•	•	•	•	•	•	•	•	•	•	•	•	•	•	•	•	•	•	•	•	•	•	•
470H			•	•	•	•	•	•	•	•	•	•	•	•	•	•	•	•	•	•	•	•	•	•	•	•	•	•	•	•	•	•	•	•	•	•
480			•	•	•	•	•	•	•	•	•	•	•	•	•	•	•	•	•	•	•	•	•	•	•	•	•	•	•	•	•	•	•	•	•	•
570			•	•	•	•	•	•	•	•	•	•	•	•	•	•	•	•	•	•	•	•	•	•	•	•	•	•	•	•	•	•	•	•	•	•
580	•	•	•	•	•	•	•	•	•	•	•	•	•	•	•	•	•	•	•	•	•	•	•	•	•	•	•	•	•	•	•	•	•	•	•	•
580J			•	•	•	•	•	•	•	•	•	•	•	•	•	•	•	•	•	•	•	•	•	•	•	•	•	•	•	•	•	•	•	•	•	•
590	•	•	•	•	•	•	•	•	•	•	•	•	•	•	•	•	•	•	•	•	•	•	•	•	•	•	•	•	•	•	•	•	•	•	•	•
690/690T			•	•	•	•	•	•	•	•	•	•	•	•	•	•	•	•	•	•	•	•	•	•	•	•	•	•	•	•	•	•	•	•	•	•
770			•	•	•	•	•	•	•	•	•	•	•	•	•	•	•	•	•	•	•	•	•	•	•	•	•	•	•	•	•	•	•	•	•	•
780			•	•	•	•	•	•	•	•	•	•	•	•	•	•	•	•	•	•	•	•	•	•	•	•	•	•	•	•	•	•	•	•	•	•
790																								•												
880																								•		•										
890/890C			•	•	•	•	•	•	•	•	•	•			•	•	•	•			•	•	•		•	•	•	•					•			
2200			•	•	•	•	•	•	•	•	•	•	•	•	•	•	•	•	•	•	•	•	•	•	•	•	•	•	•	•	•	•	•	•	•	•
2300			•	•	•	•	•	•	•	•	•	•	•	•	•	•	•	•	•	•	•	•	•	•	•	•	•	•	•	•	•	•	•	•	•	•
2300B			•	•	•	•	•	•	•	•	•	•	•	•	•	•	•	•	•	•	•	•	•	•	•	•	•	•	•	•	•	•	•	•	•	•
2400			•	•	•	•	•	•	•	•	•	•	•	•	•	•	•	•	•	•	•	•	•	•	•	•	•	•	•	•	•	•	•	•	•	•
2400H			•	•	•	•	•	•	•	•	•	•	•	•	•	•	•	•	•	•	•	•	•	•	•	•	•	•	•	•	•	•	•	•	•	•

† Saf-Tite Product

* Industrial Application

CAUTION: Verify that both the coupling's and drawbar eye's rated capacities meet your application(s) requirements.



Saf-Tite 100-4 / 100-4H Coupling

SPECIFICATIONS AND LOAD CAPACITIES

SAFETY WARNING

This product is designed for towing under normal conditions within the stated gross trailer weight. Do not overload or abuse this product. Overloading or abuse may lead to property damage, severe injury, or death.

Gross Trailer Weight:	110,000 lbs.	(49,896 kg)
Maximum Tongue Weight:	20,000 lbs.	(9,071 kg)
Ultimate Latch Capacity:	20,000 lbs.	(9,071 kg)
Maximum Eye X-Section:	1 13/16 in.	(46 mm)
Minimum Eye Opening:	2 3/8 in.	(60 mm)
Model 100-4 Unit Weight:	34.5 lbs.	(15.6 kg)
Model 100-4H Unit Weight:	34.8 lbs.	(15.8 kg)

100-4 STANDARD INSTALLATION DRAWING

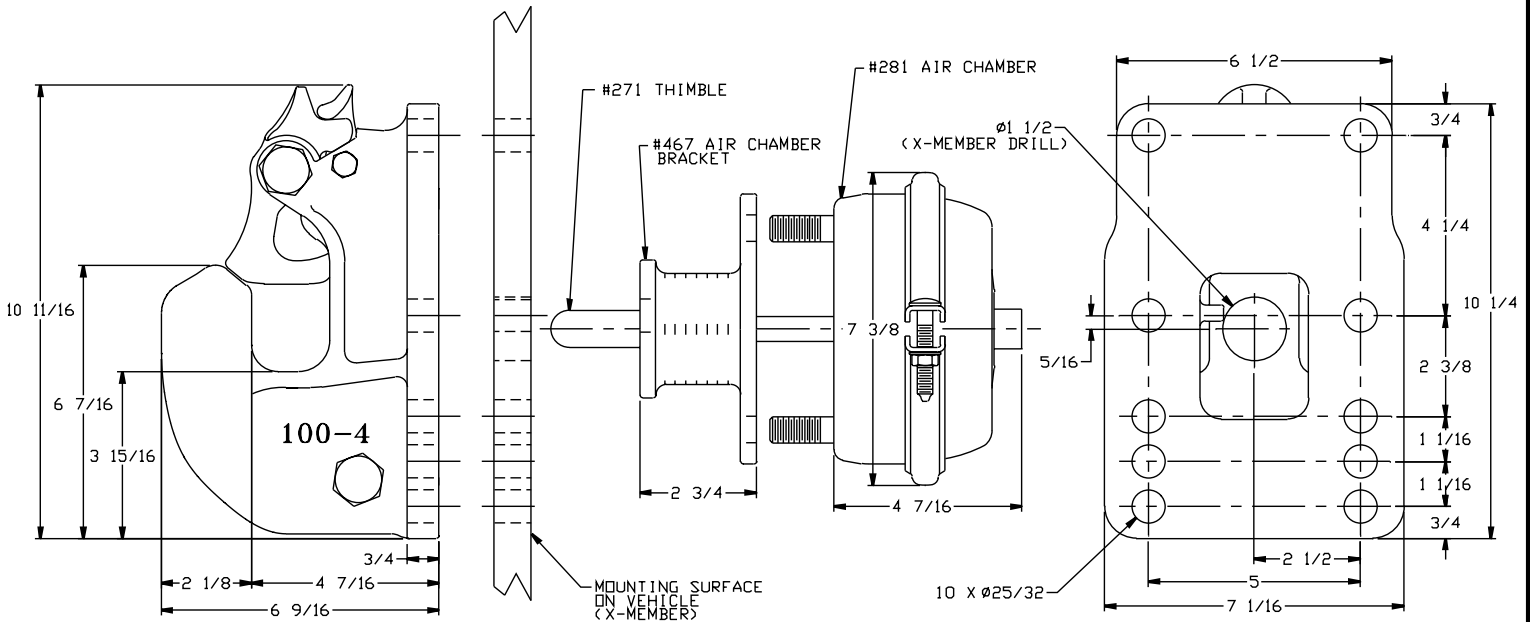

Pushrod length is 3 1/8 in. (79 mm) plus thickness of mounting structure for standard installations as illustrated.

100-4H STANDARD INSTALLATION DRAWING

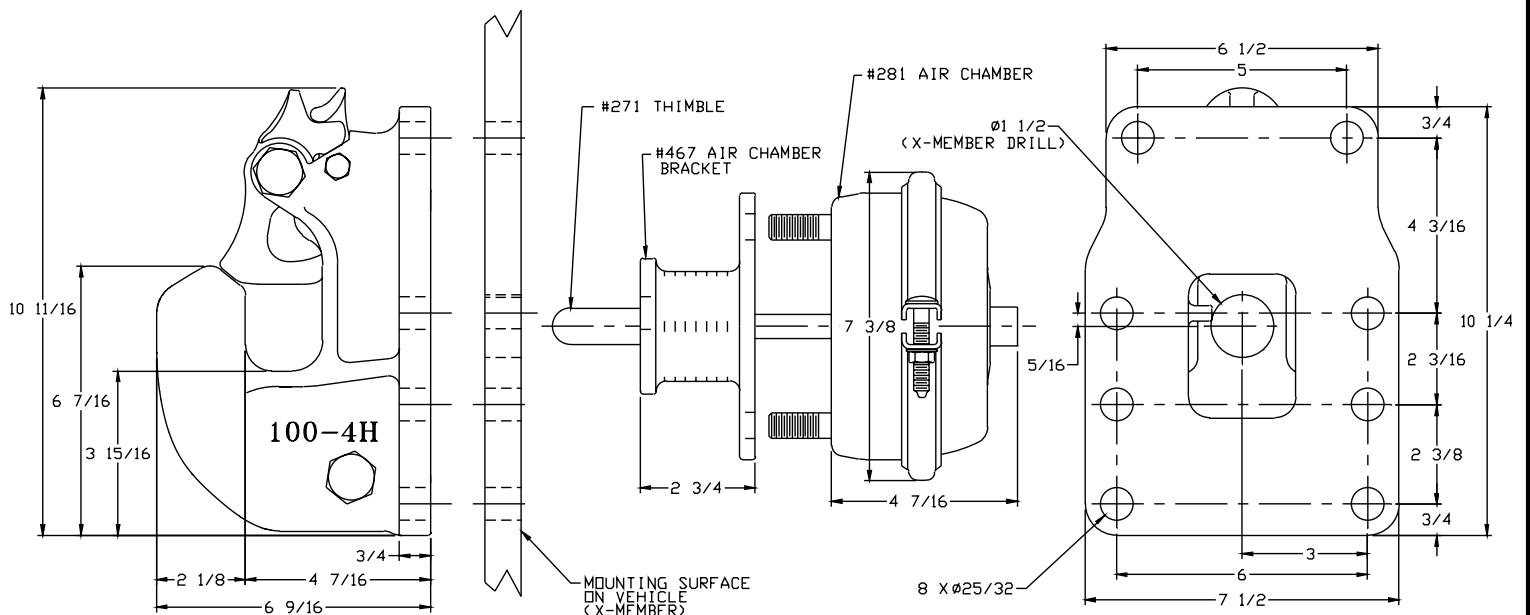

Pushrod length is 3 1/8 in. (79 mm) plus thickness of mounting structure for standard installations as illustrated.



Saf-Tite 100-4 / 100-4H Coupling

REPLACEMENT PART INFORMATION

- | | |
|-----------------|----------------|
| 102: Bolt | 274A: Lock Nut |
| 132: Latch | 266: Spring |
| 132A: Spring | 271: Thimble |
| 132B: Bushing | 274: Bolt |
| 133: Latch Lock | 274A Locknut |
| 133A: Spring | 279: Shoe |
| 101: Bolt | |
| 134B: Bushing | |
| 101A: Lock Nut | |

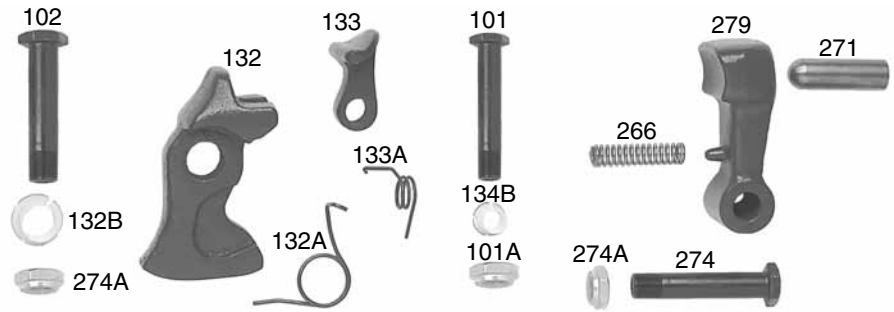

PARTS

Coupling only:

- 100-4 Coupling
- 100-4H Coupling

Parts Included with 100-4A:

- | | |
|-------------------|-----------------------------------|
| - 100-4 Coupling | - 467 Air Chamber Adapter Bracket |
| - 508 Bolt Kit | - 271 Thimble |
| - 281 Air Chamber | |

Parts Included with 100-4HA:

- | | |
|-------------------|-----------------------------------|
| - 100-4H Coupling | - 467 Air Chamber Adapter Bracket |
| - 508 Bolt Kit | - 271 Thimble |
| - 281 Air Chamber | |

ACCESSORIES

Optional Accessories:

- Air Chamber 282 Type-30: Provides a larger diaphragm for greater shoe force compared to 281 Air Chamber.
- Air Chamber Brackets: 467H (3/4 in. / 19 mm), 467F (5 1/2 in. / 140 mm)
- Thimbles: 271B (4 3/8 in. / 111 mm), 271C (5 1/2 in. / 140 mm)
- Wear Gage 14014 (2 1/8 in.): To determine hook wear limits.
- Latch Gage 14026: To determine latch gap limit.

INSPECTION / OPERATION / MAINTENANCE

The 100-4/100-4H Coupling is only to be used and maintained with Premier parts listed in the Replacement Part Information section. Any substitution or use of non-Premier parts in a 100-4/100-4H Coupling will VOID ALL PRODUCT WARRANTY.

Installation Procedure:

1. The 100-4/100-4H Coupling must be installed to comply with the Federal Motor Carrier Safety

Regulations. Specifically, Section 393.70, Paragraph C: "Towing of Full Trailers." Prior to install or operation, consult with local, State and Federal agencies, as there may be additional applicable laws governing installation and use of this product.

2. Make certain that the cross member the 100-4/100-4H Coupling is to be mounted on is of sufficient strength to withstand the load rating of the coupling.



Saf-Tite 100-4 / 100-4H Coupling

INSTALLATION

3. If using the 100-4/100-4H Coupling with a 281 Air Chamber, a 467 Air Chamber Bracket and a 271 Thimble, measure the mounting structure thickness and cut the pushrod on the air chamber to a length of 3 1/8" plus the mounting structure thickness (i.e. 1/2" thick mounting structure would equate to: 3 1/8" + 1/2" = 3 5/8" pushrod).
4. **100-4:** Has two top sets and three bottom sets of base mounting holes (10 holes total). Both top two sets must always be used (all 4 holes). For the bottom sets: drill *either* the center set of holes only (for a total of 6 mounting holes), *or* drill only the two furthest apart sets of holes (for a total of 8 mounting holes).
100-4H: ALL mounting hole sets must be used.
5. Using the Standard Installation Drawing, measure and layout the cross member and then drill the holes for the mounting bolts (and pushrod if used with an air chamber).
6. Mount the 100-4/100-4H Coupling using either Premier's 508 Bolt Kit and provided torque value, or eight other 3/4" grade-8 bolts and grade-C locknuts. Only use new fasteners when mounting couplings or drawbar eyes and torque to SAE specifications. If using the 100-4/100-4H Coupling with a 281 Air Chamber, mount the chamber, 467 Air Chamber Bracket and 271 Thimble as shown in the Standard Installation Drawing. The two longer (2 3/4") mounting bolts in the bolt kit are used for mounting the coupling and air chamber bracket to the cross member.
WARNING: Never use an air chamber on a Premier coupling without a 271 Series Thimble.
7. Once mounted, check the latch components for proper operation and clearances (see the Inspection/Operation/Maintenance section for opening and closing the latch). If the operation of the latch components is sticky, lubricate all rotation points with a light penetrating oil. Work the latch assembly several times to distribute the lubricant evenly and remove any excess with a rag. Do not apply lubricant to the pintle/hook or saddle area of the 100-4/100-4H Coupling.
8. Plumb the air line to the 281 Air Chamber from the vehicle's emergency side air supply. NEVER use the service side air supply.
9. **WARNING!** Keep hands clear of the 100-4/100-4H Coupling during this test. Activate the emergency side air supply by releasing the emergency brake and visually verify that the 279 Shoe fully rotates toward the pintle.
10. If the 279 Shoe does not move, verify that the 281 Air Chamber has been connected to the emergency side air supply and that the pushrod length is correct.
11. When the emergency side air supply is removed, the shoe should completely retract. Please note: The 279 Shoe acts as a shock absorbing device to help smooth the ride between vehicles. It is not considered part of the latching mechanism.
12. An "IMPORTANT WARNINGS!" sticker was enclosed. This must be attached to the coupling or cross member and be visible for the end user to read.

INSPECTION / OPERATION / MAINTENANCE

Inspection and Maintenance:

1. Visually inspect the coupling body and latch components for cracks, impact damage and/or deformation before each and every use. Do NOT use if any of these conditions exist.
2. Check the gap between the latch and top of the pintle/hook on the coupling body before each and every use. A gap of 3/8" or more means the coupling must be taken out of service and repaired or replaced.
3. If the wear area on the pintle/hook has worn 20% or more from its original cross-section, the coupling is considered out-of-service and must NOT be used.
4. Lubrication of the latch components must be performed at 90-day intervals or sooner depending on the operating environment.



Saf-Tite 100-4 / 100-4H Coupling

INSPECTION / OPERATION / MAINTENANCE

Lubricate the latch components with a spray-type lubricant to evenly coat all rotation points. Rotate each latch component several times to evenly distribute the lubricant.

5. Remove any excess lubricant with a rag. Do not apply lubricant to the pintle/hook or saddle area of the coupling.
6. Never weld on any Premier part in order to repair damaged or worn areas. Field and/or shop welds are inadequate and may further weaken the coupling.
7. **WARNING:** Other inspection and maintenance

procedures are also required prior to the operation of combination vehicles. Consult and follow all Federal Motor Carrier Safety Regulations as well as local, state and federal guidelines.

Operation:

Operating Coupling Latch:

1. While facing the mounted 100-4/100-4H Coupling, push the 133 Latch Lock toward the mounting plate (away from you) until full rotational travel is reached. While holding the latch lock in the open position, grasp the top of the 132 Latch and pull out toward the pintle, rotating the latch until full rotational travel is reached.
2. Holding the 132 Latch in place, slowly release the 133 Latch Lock until it has rotated into the latch.
3. Release the 132 Latch and the 100-4/100-4H Coupling is now open and ready to couple or uncouple.

Closing Coupling Latch:

4. Rotate the top of the 132 Latch toward the pintle until full rotational travel is reached. Push the 133 Latch Lock toward the mounting plate as far as it will go.
5. While holding the 133 Latch Lock in this position, slowly release the 132 Latch. Release the latch lock making sure it seats fully down in the slot on top of the latch. The 100-4/100-4H Coupling latch is now closed.
6. To test for proper latching, apply a force toward the coupling body to the front of the 132 Latch (down near the top of the pintle). **THE LATCH SHOULD NOT OPEN!** If the latch does not stay closed, do not use until it has been repaired or replaced.
7. This product is designed to be operated within its free rotation limits. It is the responsibility of the vehicle designer/end user to ensure that these limits are not exceeded (do not bind-up/jackknife).
8. **WARNING:** Prior to towing, make certain that adequately rated safety chains have been properly connected.

IMPORTANT GUIDELINES that apply to all Premier Air Adjusted Couplings

- Do not weld on any coupling assembly
- Always use Grade-8 fasteners properly torqued
- Do not apply lubricants to the coupling hook
- Air service chamber must be Type-24 or Type-30 with 90-120 PSI air supply

- Clean & inspect coupling for damage & excessive wear prior to each and every use
- Lubricate all coupling components at a minimum of 90 day intervals
- Do not bind-up (Jackknife) any application as stresses can cause damage to products or components, resulting in failure and detachment of the trailer while in use



ATTENTION !

End Users must read and follow this information.

DISTRIBUTORS & OEM'S: Please ensure that your customers are made aware of the following information on this page.

- (1) **VERIFY THAT BOTH COUPLING'S AND DRAWBAR EYE'S RATED CAPACITIES MEET YOUR APPLICATION(S) REQUIREMENTS.**
- (2) DO NOT OVERLOAD COUPLING OR DRAWBAR EYE.
- (3) INSPECT COUPLING, LATCH AND DRAWBAR EYE FOR CRACKS, BENDING DAMAGE OR EXCESSIVE WEAR. **DO NOT USE IF ANY OF THESE CONDITIONS EXIST!**
- (4) CHECK FOR GAP BETWEEN CLOSED LATCH AND TOP OF HORN OR COUPLING BALL. **DO NOT USE IF GAP IS 3/8 IN. OR MORE.**
- (5) MAKE SURE COUPLING IS LATCHED AND THAT LATCH WILL NOT OPEN.
- (6) PRIOR TO USE, ALWAYS CONNECT SAFETY CHAINS OF ADEQUATE STRENGTH FOR LOAD(S) BEING TOWED.
- (7) DO NOT BIND-UP (JACKKNIFE) ANY APPLICATION AS STRESSES CAN CAUSE DAMAGE TO THE COUPLING, DRAWBAR EYE, OTHER COMPONENTS OR ANY COMBINATION OF THEM. JACKKNIFING MAY RESULT IN FAILURE OF PRODUCTS OR COMPONENTS, RESULTING IN DETACHMENT OF THE TRAILER WHILE IN USE.
- (8) DO NOT APPLY LUBRICANTS TO THE COUPLING HOOK OR DRAWBAR EYE LOOP, AS THEY CAN COVER UP POSSIBLE DAMAGE AND ACCELERATE WEAR.
- (9) ALWAYS ABIDE BY ALL APPLICABLE STATE AND FEDERAL REGULATIONS GOVERNING SAFE AND PROPER TRANSPORTATION.
- (10) NEVER STRIKE ANY OF THESE COMPONENTS WITH A HAMMER OR ANY OTHER DEVICE.
- (11) ALWAYS VERIFY PROPER OPERATION OF LATCHING SYSTEM AND COUPLING COMPONENTS PRIOR TO DRIVE OFF.
- (12) NEVER USE A COUPLING THAT YOU DO NOT FULLY UNDERSTAND HOW TO PROPERLY OPERATE AND VERIFY SECURE LATCHING OF.
- (13) **NEVER REPLACE ANY PART IN ANY OF PREMIER'S ASSEMBLIES WITH NON-PREMIER COMPONENTS. DOING SO WILL VOID ALL WARRANTY AND POTENTIALLY COMPROMISE THE UNIT'S INTEGRITY, WHICH COULD RESULT IN PROPERTY DAMAGE, SERIOUS INJURY, OR DEATH.**



WARNING!

This envelope contains important instructions AND MUST REMAIN ATTACHED TO THIS COUPLING. It may be removed only by the End User or by an Original Equipment Manufacturer who preserves this envelope and instructions and provides it to the end user.



PREMIER MANUFACTURING COMPANY
THE FIRST NAME IN QUALITY COUPLINGS
800-255-5387 (503) 234-9202
www.premier-mfg.com

Saf-Tite 100-4 / 100-4H Coupling
Installation, etc.
Revised: 01/12

WARRANTY: We warrant all Premier products to be free from defects in material or workmanship for one year. We will repair or replace, at our option, any Premier product which our examination reveals to be defective, provided that the product is returned to our factory, at Tualatin, Oregon transportation prepaid, within one year of purchase by the first retail purchaser. Our warranty does not extend to products which have been subject to misuse, neglect, improper installation, maintenance or application, nor does our warranty extend to products which have been repaired or altered outside of Premier's facility unless the repair or alteration has been expressly authorized in writing by Premier. ***This warranty is in lieu of all other warranties, express or implied, and excludes warranties of merchantability, fitness for a particular purpose and otherwise, and in no event will Premier be liable for incidental, special, contingent or consequential damages.***

DISCLAIMER: Although great care has been taken to ensure accurate information throughout this document, Premier Manufacturing Company must reserve the right to alter any information contained within. These changes include but are not limited to: Dimensional changes, load capacity and availability of any part or assembly.

© 2009 Premier Manufacturing Company

All rights reserved. Any reproduction of the photographic images or any other portion of this document, including but not limited to the photocopying, or retention and/or storage in a retrieval system of any kind, is strictly prohibited without prior express written permission from Premier Manufacturing Company.

