



PREMIER
MANUFACTURING

Document #10006318

THE FIRST NAME IN QUALITY COUPLINGS

Installation, Inspection, Operation & Maintenance Guide



MODEL 235NT COUPLING

PART #10001113

IMPORTANT

Read these instructions completely before installing, using or attempting to repair this product. If you have any questions, call Premier at (800) 255-5387 or (503) 234-9202

SELECTING THE RIGHT EQUIPMENT

Whatever your application, selecting the proper equipment for the job is very important. Proper selection along with regular inspection and maintenance will help keep operating costs minimal while providing long life to each component. Below are general guidelines for selecting Premier Coupling and Drawbar Eyes. If you feel that your application is unique, please give Premier a call so that we may help you through the selection process.

Follow these four steps to ensure proper selection of Premier Couplings and Drawbar Eyes.

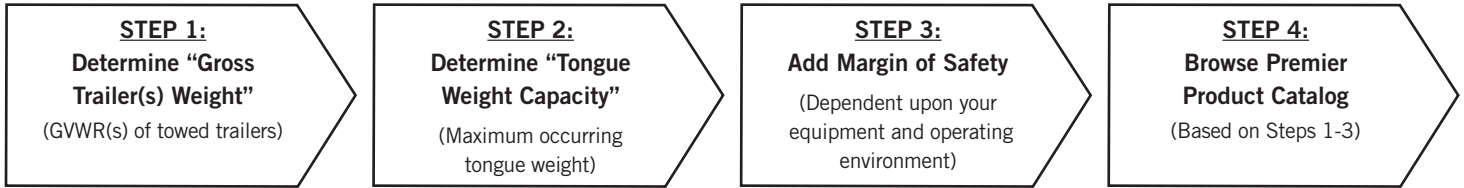

STEP 1: Determine "Gross Trailer(s) Weight"

"Gross Trailer(s) Weight" is usually determined by the Gross Vehicle Weight Rating (GVWR). This information is attached to the trailer by the trailer manufacturer.

For "Double Trailer" configurations, only the rear trailer is considered when selecting your Premier Coupling or Drawbar Eye. In this example, a Coupling and Drawbar Eye with a "Gross Trailer Weight" rating of 40,000 lbs. (18,143 kg) would be the minimum rating acceptable for normal, over-the-road applications (see Tongue Weight section below).

Double Trailer Configuration



Example only, each application may vary and should be considered unique.

For "Triple Trailers", only the two most rearward trailers are considered in selecting your Premier Coupling or Drawbar Eye. In this example, a Coupling and Drawbar Eye with a "Gross Trailer Weight" rating of 80,000 lbs (36,287 kg) would be the minimum acceptable for normal, over-the-road applications. (See Tongue Weight section below).

Triple Trailer Configuration



Example only, each application may vary and should be considered unique.

STEP 2: Determine "Tongue Weight Capacity"

"Tongue Weight Capacity" is the maximum expected weight at the drawbar eye. If a hinged drawbar is used, the maximum weight will be approximately 1/2 the overall drawbar weight. If a non-hinged drawbar is used and the actual tongue weight is not known, you can approximate the weight by multiplying the GVWR of the towed trailer by 15%. However, each application is unique and the best practice is to weigh the tongue when the trailer is loaded to GVWR.



STEP 3: Consider Operating Conditions and Environments

Environments such as rough uneven roads or off-road use can dramatically increase shock loads to both drawbar eyes and couplings. In general, increasing the "Gross Trailer Weight" (Step 1:) and "Tongue Weight Capacity" (Step 2:) by a minimum of 25% will be sufficient for many applications. Even if an application is used off-road occasionally, the minimum increase necessary for Gross Trailer and Tongue Weight is 25%. Certain types of equipment and/or operating practices can also dramatically increase loads through equipment binding and/or improper loading practices. Of special concern is high tongue weight. However, each application is unique and every environment different, therefore your application may require more than 25%.

Once both "Gross Trailers(s) Weight" (Step 1:) and "Tongue Weight Capacity" (Step 2:) have been determined, evaluate your operating conditions and apply an appropriate margin of safety.

STEP 4: Browse Premier Product Catalog

Browse the Premier Product Catalog and refer to the "Specifications" section of each product. Be sure to review the "Understanding Premier Load Specifications" sections and "Coupling to Drawbar Eye Cross-Reference" sheet on the next couple of pages.

SELECTING THE RIGHT EQUIPMENT

Understanding Premier Load Specifications

Each Premier product undergoes extensive design and testing prior to being introduced. We use the latest in Computer Aided Design and Analysis Software as well as physical destructive tests. Premier's published load specifications are the maximum load a given product or part will withstand without failure. Premier's testing procedures closely follow the Society of Automotive Engineers (SAE) guidelines of Recommended Practice for testing Couplings and Drawbar Eyes (SAE J847 & J849).

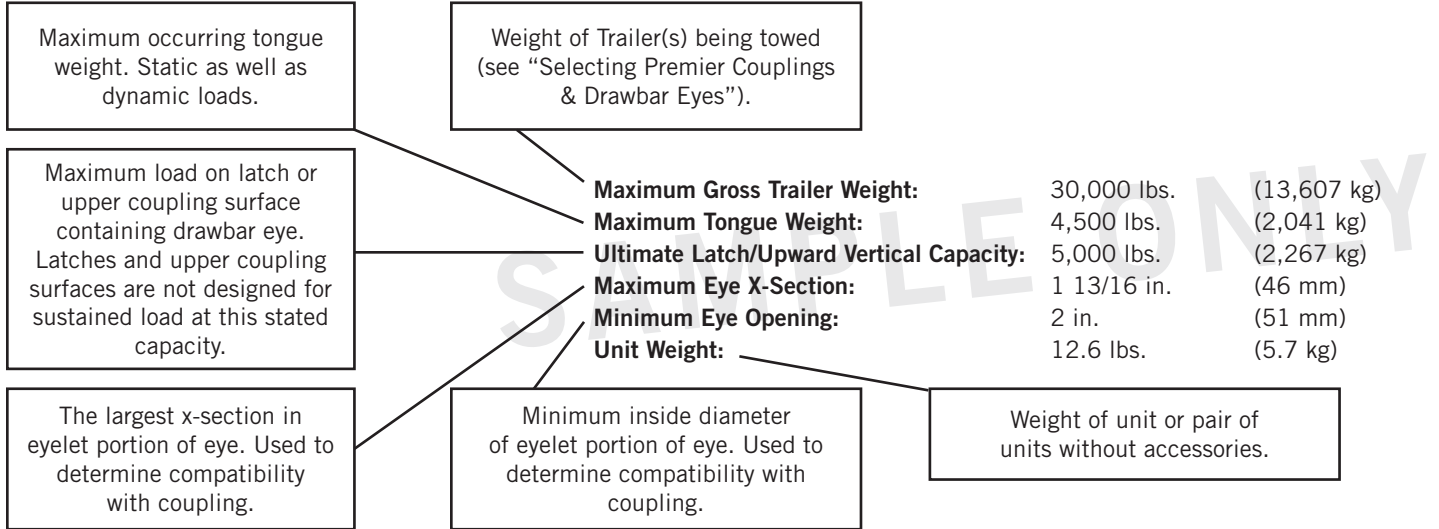

Importance of Inspection and Maintenance

Whether you use Premier Jacks, Couplings, Drawbar Eyes, Hinge Assemblies or any other Premier product, regular inspection and maintenance are essential for proper function, keeping repair costs to a minimum and above all, safe and efficient operation.

To determine wear limits, Premier created Wear Gages that help judge the useful life of couplings and drawbar eyes (details in catalog). In accordance with Premier and the Federal Motor Carrier Safety Regulations, these were designed to identify wear at the critical percentages of 18% and 20%, by measuring the cross-section of coupling hooks (horn) and drawbar eye loops. 18% wear indicates that the product should be replaced as soon as possible. At 20% wear, the product is no longer in usable condition and must be taken out of service immediately and replaced. The latch gage bar measures the gap space between the top of the coupling hook and the closed latch. If the 3/8" latch gage bar can pass between this region, then the latch components should be considered worn past safe limits and replaced. Please note that these wear gage specifications are in accordance with Premier Mfg. and the Federal Motor Carrier Safety Regulations (refer to other manufacturer's specifications for wear limits on their products).



Premier also provides Installation Guides for each of our major products. These help guide you through installation, inspection, routine maintenance and part replacement. Another resource is our website at www.premier-mfg.com. Here you will find Installation Guides, Service Guides, distributor locations, online catalogs, product information, trade show schedules and links to trucking resources.

Additional Product Resources at Your Fingertips

Customer Service: We are always here to support you. Do you need additional information or assistance? Your phone calls are greeted by our courteous receptionist, during business hours. We have exceptional, personable Customer Service Reps for you to rely on. If you have product questions or want to place an order, you can speak directly with one of our experienced and knowledgeable Customer Service Representatives.

Sales Representatives: Would you like on site training or assistance? Contact one of our veteran Premier Sales Reps for more information about product training for your staff. Or be sure to visit with them at a Trade Show (see website for schedule).

www.premier-mfg.com: Our website is an informative resource at your fingertips. In addition to our Installation and Service Guides, you will find Territory Manager contact information, distributor locations, product specifications, product selectors, cross-reference forms, digital product catalog, trade show schedule, and links to trucking resources.

MODEL 235NT COUPLING

Specifications and Load Capacities

SAFETY WARNING

This product is designed for towing under normal conditions within the stated gross trailer weight. Do not overload or abuse this product. Overloading or abuse may lead to property damage, severe injury, or death.

Gross Trailer Weight:	60,000 lbs.	(27,215 kg)
Maximum Tongue Weight:	12,000 lbs.	(5,443 kg)
Ultimate Latch Capacity:	20,000 lbs.	(9,071 kg)
Maximum Eye X-Section:	1 11/16 in.	(43 mm)
Minimum Eye Opening:	2 1/8 in.	(54 mm)
Unit Weight:	32 lbs.	(14.5 kg)

Standard Installation Drawing

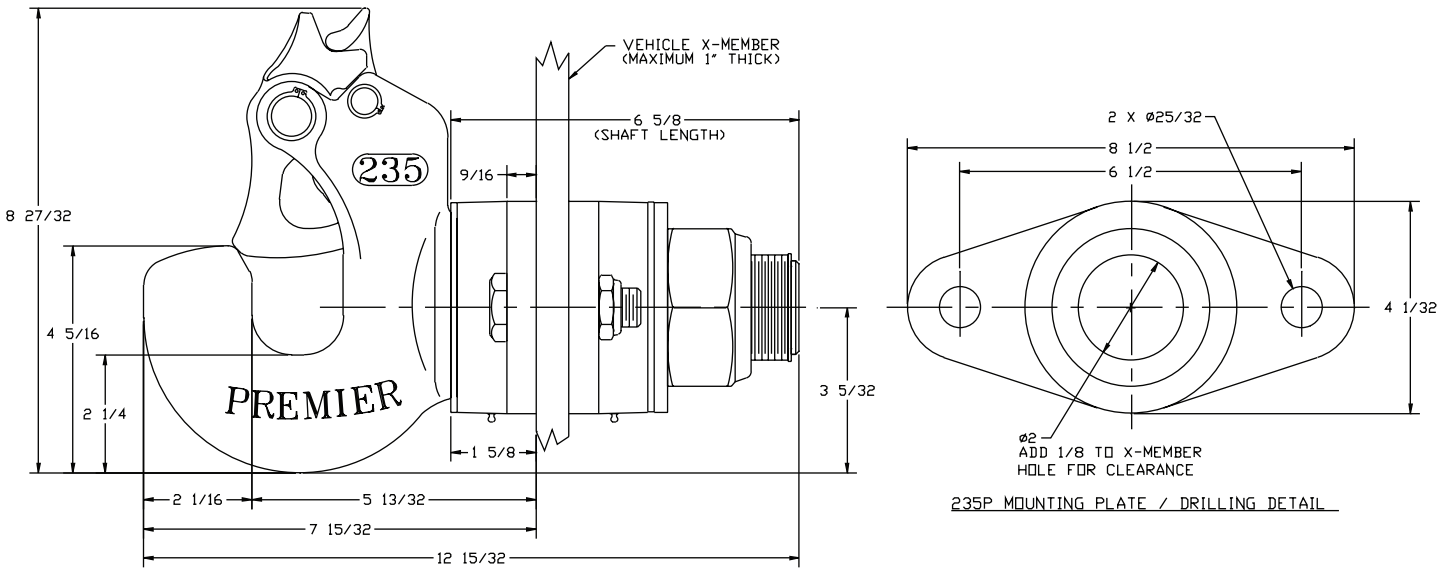

MODEL 235NT COUPLING

Replacement Part Information

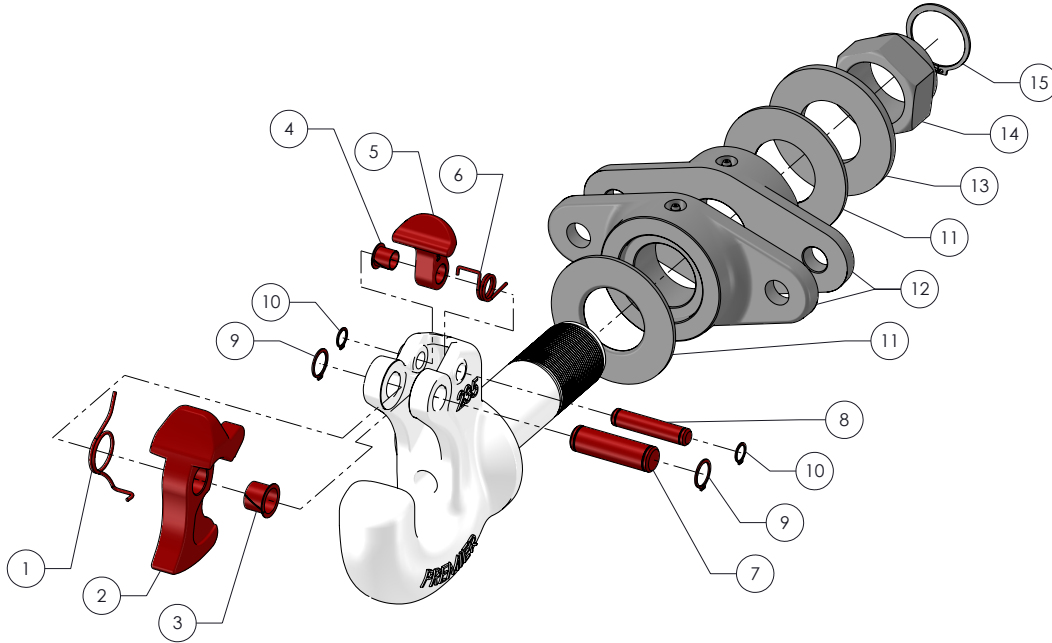

Model 235NT Parts available:

Item	Model #	Part #	Description
	135PK	10001054	Parts Kit
1	132A	10000211	Spring
2	132	10000210	Latch
3	132B	10000212	Bushing
4	134B	10000219	Bushing
5	133	10000214	Latch Lock
6	135A	10001046	Spring
7	131	10004670	Pin w/ Snap Rings
8	134	10004671	Pin
9	144-75	10001069	Snap Ring (2)
10	275-50	10000311	Snap Ring (2)

Item	Model #	Part #	Description
11	*237NT	10001119	Nylatron Bushing (2)
12	*235P	10001115	Mounting Plate (2)
13	*238	10001120	Washer
14	*416	10001181	Locknut
15	*208	10001106	Snap Ring

*Not included in parts kit, available individually.

Optional Accessories

Optional Accessories:

- 14026 Latch Gage (#10000071): To determine latch gap limit.
- 14011 Wear Gage (#10000059): To determine hook wear limits.

MODEL 235NT COUPLING

Installation

NOTE: DO NOT USE SWIVEL-TYPE DRAWBAR EYES WITH THE 235NT COUPLING.

The 235NT Coupling is only to be used and maintained with Premier parts listed in the Replacement Part Information section. Any substitution or use of non-Premier parts in a 235NT Coupling will VOID ALL PRODUCT WARRANTY.

Installation Procedure

1. The 235NT Coupling must be installed to comply with the Federal Motor Carrier Safety Regulations. Specifically, Section 393.70, Paragraph C: "Towing of Full Trailers." Prior to install or operation, consult with local, State and Federal agencies, as there may be additional applicable laws governing installation and use of this product.
2. Make certain that the cross member the 235NT Coupling is to be mounted on is of sufficient strength to withstand the load rating of the coupling.
3. Using the Standard Installation Drawing, measure and layout the cross member and then drill the holes. Note: Center hole for the 235NT shaft is to be drilled to $\varnothing 2 \frac{1}{8}$ in. (54mm).
4. Mount both 235P Mounting Plates using two $\frac{3}{4}$ " grade-8 bolts and grade-C locknuts, leaving each bolt slightly loose. This will help in aligning the main shaft.
5. Generously lubricate both faces of both 237NT Bushings. Slide one 237NT Bushing over the coupling shaft, the 237NT's fillet should face the 235 coupling body, and insert the shaft through both 235P Mounting Plates (use extreme care not to damage the threads on the shaft). Slide the other 237NT Bushing over the shaft (there is no specific orientation required for the second 237NT).
6. Clean and lubricate all visible threads on the shaft
7. Slide the 238 Washer and thread the 416 Locknut on the shaft. Tighten the locknut until all slack between the 235NT Coupling body and the 235P Mounting Plates has been removed. Continue to tighten the locknut until the desired rotational stiffness of the coupling is acquired. Install the 208 Snap Ring into the groove at the end of the shaft. **WARNING: Do NOT rotate the coupling body to tighten the nut.**
8. Tighten each $\frac{3}{4}$ " bolt and mating locknut. Only use new fasteners when mounting couplings or drawbar eyes and torque to SAE specifications.
9. Grease both 235P Mounting Plates at the zerk fittings. Each mounting plate should take a minimum of 3-4 pumps using a mechanical grease gun.
10. Once mounted, check the latch components for proper operation and clearances (see the Inspection/Operation/Maintenance section for opening and closing the latch). If the operation of the latch components is sticky, lubricate all rotation points with a light penetrating oil. Work the latch assembly several times to distribute the lubricant evenly and remove any excess with a rag. Do not apply lubricant to the pintle/hook or saddle area of the 235NT Coupling.
11. An "IMPORTANT WARNINGS!" sticker was enclosed. This must be attached to the coupling or cross member and be visible for the end user to read.

Inspection/Operation/Maintenance

Inspection and Maintenance:

1. Visually inspect the coupling body and latch components for cracks, impact damage and/or deformation before each and every use. Do NOT use if any of these conditions exist.
2. Check the gap between the 132 Latch and the top of the pintle/hook on the coupling body before each and every use. A gap of $\frac{3}{8}$ " or more means the coupling must be taken out of service and repaired or replaced.
3. If the wear area on the pintle/hook has worn 20% or more from its original cross-section, the coupling is considered out-of-service and must NOT be used.
4. Lubrication of the latch components must be performed at 90-day intervals or sooner depending on the operating environment. Lubricate the latch components with a spray-type lubricant to evenly coat all rotation points. Rotate each latch component several times to evenly distribute the lubricant. Lubricate the mounting plates at the grease zerks using a mechanical grease gun.
5. Remove any excess lubricant with a rag. Do not apply lubricant to the pintle/hook or saddle area of the coupling.
6. Check for wear on both 237NT Bushings. Any slack should be removed by tightening the 416 Locknut. Excessively worn 237NT Bushings should be replaced immediately.
7. Never weld on any Premier part in order to repair damaged or worn areas. Field and/or shop welds are inadequate and may further weaken the coupling.
8. **WARNING:** Other inspection and maintenance procedures are also required prior to the operation of combination vehicles. Consult and follow all Federal Motor Carrier Safety Regulations as well as local, state and federal guidelines.



MODEL 235NT COUPLING

Operations

Operation:

OPENING Coupling Latch

1. While facing the mounted 235NT Coupling, push the 133 Latch Lock toward the mounting plate (away from you) until full rotational travel is reached. While holding the latch lock in this position, grasp the top of the 132 Latch and pull out toward the pintle, rotating the latch until full rotational travel is reached.
2. Holding the 132 Latch in place, slowly release the 133 Latch Lock until it has rotated into the latch.
3. Release the 132 Latch and the 235NT Coupling is now open and ready to couple or uncouple.

CLOSING Coupling Latch

4. Rotate the top of the 132 Latch toward the pintle until full rotational travel is reached. Push the 133 Latch Lock toward the mounting plate as far as it will go.
5. While holding the 133 Latch Lock in this position, slowly release the 132 Latch. Release the latch lock making sure it seats fully down in the slot on top of the latch. The 235NT Coupling latch is now closed.
6. To test for proper latching, apply a force toward the coupling body to the front of the 132 Latch (down near the top of the pintle). THE LATCH SHOULD NOT OPEN! If the latch does not stay closed, do not use until it has been repaired or replaced.
7. This product is designed to be operated within its free rotation limits. It is the responsibility of the vehicle designer/end user to ensure that these limits are not exceeded (do not bind-up/jackknife).
8. **WARNING:** Prior to towing, make certain that adequately rated safety chains have been properly connected.

IMPORTANT GUIDELINES that apply to all Premier Non-Air Couplings

- Do not weld on any coupling assembly
- Always use Grade-8 fasteners properly torqued
- Do not apply lubricants to the coupling hook
- Clean & inspect coupling for damage & excessive wear prior to each and every use
- Lubricate all coupling components at a minimum of 90 day intervals
- Do not bind-up (Jackknife) any application as stresses can cause damage to products or components, resulting in failure and detachment of the trailer while in use.



ATTENTION!

End Users must read and follow this information.

DISTRIBUTORS & OEM'S: Please ensure that your customers are made aware of the following information on this page.

1. VERIFY THAT BOTH COUPLING'S AND DRAWBAR EYE'S RATED CAPACITIES MEET YOUR APPLICATION(S) REQUIREMENTS.
2. DO NOT OVERLOAD COUPLING OR DRAWBAR EYE.
3. INSPECT COUPLING, LATCH AND DRAWBAR EYE FOR CRACKS, BENDING DAMAGE OR EXCESSIVE WEAR.
DO NOT USE IF ANY OF THESE CONDITIONS EXIST!
4. CHECK FOR GAP BETWEEN CLOSED LATCH AND TOP OF HORN OR COUPLING BALL.
DO NOT USE IF GAP IS 3/8 IN. OR MORE.
5. MAKE SURE COUPLING IS LATCHED AND THAT LATCH WILL NOT OPEN.
6. PRIOR TO USE, ALWAYS CONNECT SAFETY CHAINS OF ADEQUATE STRENGTH FOR LOAD(S) BEING TOWED.
7. DO NOT BIND-UP (JACKKNIFE) ANY APPLICATION AS STRESSES CAN CAUSE DAMAGE TO THE COUPLING, DRAWBAR EYE, OTHER COMPONENTS OR ANY COMBINATION OF THEM. JACKKNIFING MAY RESULT IN FAILURE OF PRODUCTS OR COMPONENTS, RESULTING IN DETACHMENT OF THE TRAILER WHILE IN USE.
8. DO NOT APPLY LUBRICANTS TO THE COUPLING HOOK OR DRAWBAR EYE LOOP, AS THEY CAN COVER UP POSSIBLE DAMAGE AND ACCELERATE WEAR.
9. ALWAYS ABIDE BY ALL APPLICABLE STATE AND FEDERAL REGULATIONS GOVERNING SAFE AND PROPER TRANSPORTATION.
10. NEVER STRIKE ANY OF THESE COMPONENTS WITH A HAMMER OR ANY OTHER DEVICE.
11. ALWAYS VERIFY PROPER OPERATION OF LATCHING SYSTEM AND COUPLING COMPONENTS PRIOR TO DRIVE OFF.
12. NEVER USE A COUPLING THAT YOU DO NOT FULLY UNDERSTAND HOW TO PROPERLY OPERATE AND VERIFY SECURE LATCHING OF.
13. **NEVER REPLACE ANY PART IN ANY OF PREMIER'S ASSEMBLIES WITH NON-PREMIER COMPONENTS. DOING SO WILL VOID ALL WARRANTY AND POTENTIALLY COMPROMISE THE UNIT'S INTEGRITY, WHICH COULD RESULT IN PROPERTY DAMAGE, SERIOUS INJURY, OR DEATH.**



WARNING!

This envelope contains important instructions
**AND MUST REMAIN ATTACHED TO THIS
COUPLING.** It may be removed only by the End
User or by an Original Equipment Manufacturer
who preserves this envelope and instructions and
provides it to the end user.



PREMIER MANUFACTURING
THE FIRST NAME IN QUALITY COUPLINGS
800-255-5387 (503)234-9202
www.premier-mfg.com

Model 235NT Coupling

WARRANTY: We warrant all Premier products to be free from defects in material or workmanship for one year. We will repair or replace, at our option, any Premier product which our examination reveals to be defective, provided that the product is returned to our factory, at Tualatin, Oregon transportation prepaid, within one year of purchase by the first retail purchaser. Our warranty does not extend to products which have been subject to misuse, neglect, improper installation, maintenance or application, nor does our warranty extend to products which have been repaired or altered outside of 3UHPLHU-V facility unless the repair or alteration has been expressly authorized in writing by Premier. **This warranty is in lieu of all other warranties, express or implied, and excludes warranties of merchantability, fitness for a particular purpose and otherwise, and in no event will Premier be liable for incidental, special, contingent or consequential damages.**

DISCLAIMER: Although great care has been taken to ensure accurate information throughout this document, Premier Manufacturing must reserve the right to alter any information contained within. These changes include but are not limited to: Dimensional changes, load capacity and availability of any part or assembly.

© 2009 Premier Manufacturing

All rights reserved. Any reproduction of the photographic images or any other portion of this document, including but not limited to the photocopying, or retention and/or storage in a retrieval system of any kind, is strictly prohibited without prior express written permission from Premier Manufacturing.

