



PREMIER
MANUFACTURING

Document #10007423

THE FIRST NAME IN QUALITY COUPLINGS

2000PK SERVICE GUIDELINES

PART #10000737

BEFORE GETTING STARTED:

- This procedure should only be performed by a qualified mechanic.
- Tools required: 1" wrench (2071), 1-1/4" wrench, 3/8" hex key (388B) 1-1/16" socket (274A), 1-7/16" socket (297) 15/16" Socket (375A), Flat bladed screw driver (2073A), Safety Glasses, Premier 14014 wear gage (#10000062)
- Measure the wear on the coupling's pintle hook. If the wear is at or exceeds 20% of the cross-section, the coupling is considered Out of Service. Do not continue.
- NOTE: These instructions cover complete disassembly and assembly of ALL of the 2000 series coupling components, including pieces not included in the 2000PK specifically. Please follow the instructions that apply to your replacement components.
- Safety glasses are required for all of the following procedures.
- Prior to disassembly, familiarize yourself with the location of all the various parts in the coupling. This will assist in the assembly process.
- See attached Image Reference Section(s) with photos and/or drawings to identify various product parts.
- These procedures apply for all of the model 1000 and 2000 Series Couplings: 1200, 1300, 14000, 1400H, 2200, 2300, 2400, 2400H, 2880; though most of the images used in this document are of the model 2200.

DISASSEMBLY:

1. The coupling should be positioned upright, as if mounted, with the latch in the closed position. See Image #2 in the Image Reference Section.
2. Locate the 2071 Bolt, which resides within the 2072 Latch, and remove the 297 Locknut from the right side. Slide the 2071 Bolt out from the left side. Rotate the 2073 Latch Lock backwards to the open position and remove the 2072A Spring and 2072 Latch. The 2072B Bushing should be inside of the 2072 Latch bolt hole.
3. Locate the 388B Bolt, which resides within the 2073 Latch Lock, and remove the 375A Locknut from the right side. Slide the 388B Bolt out from the left side and remove the 2073 Latch Lock; 2073A Spring; 2073B Bushing; and 373B Spacer.
4. IF you are replacing the 279 Shoe and its components, then follow instructions below:
Otherwise, continue on to #5.
Locate the 274 Bolt which resides within the 279 Shoe at the bottom of the coupling and remove the 274A Locknut from the right side. Slide the 274 Bolt out from the left side and remove the 279 Shoe and 266 Spring.
5. With all parts removed from the coupling body, clean and inspect the body for wear and/or damage. If wear exists or damage is noted, do not attempt to repair. DO NOT ATTEMPT WELD REPAIR OF ANY DAMAGED AND/OR WORN PART.

DISASSEMBLY IS COMPLETE



IMPORTANT NOTES TO CLEAN, INSPECT & LUBRICATE:

- Use only genuine PREMIER replacement parts on any repairs. Use of other parts, which can have different specifications or tolerances, may fail to alert you to non-obvious damage to the hitch which can lead to hitch failure.
- All body holes, part holes and pins need to be thoroughly cleaned and lubricated with heavy grease before the parts are reassembled. **DO NOT LUBRICATE PINTLE HOOK WEAR SURFACE.**
- Do not over-tighten fasteners as this may cause damage.

ASSEMBLY:

Prior to assembly, place the 2072B Bushing in the 2072 Latch. Align the latch with the upper coupling body holes and slide the 2071 Bolt through the holes. Rotate the latch to the closed position and measure the gap between the latch and top of the pintle. If the gap is 3/8" or more, the coupling body is damaged and must be replaced. If the gap is less than 3/8", remove the bolt, latch and bushing and begin assembly.

1. IF you are replacing the 279 Shoe and its components, then follow instructions below:
Otherwise, continue on to #2.
Place the 266 Spring over the nipple on the 279 Shoe. Insert as assembled through the opening at the top of the coupling and into the cavity at the bottom. The 266 Spring should seat into the concave cavity, which resides below the pintle base. The 266 Spring must be slightly compressed to align the 279 Shoe hole with the bottom body hole. From the left side of the body, insert the 274 Bolt (left to right) into the bottom coupling body hole and secure on the right side with 274A Locknut. Make certain that one of the flats of the 274 Bolt head is flush with the flat on the body sidewall. Rotate the 279 Shoe to verify proper spring tension.
2. Take the 388B Bolt and insert it into the left side body hole, allowing approximately 1/2" to extend past the left side interior wall surface.
3. Hold the 2073A Spring so that the straight leg is pointing upward on the left side of the spring and the hooked leg is on the right. Place the spring onto the extending end of the 388B Bolt, within the body cavity. The straight spring leg should be along the top ledge, pointing toward you.
4. Insert the 2073B Bushing into the right side of the 2073 Latch Lock hole (see Image #1), until the bushing flange is tight against the outside edge. Position the 2073 Latch Lock into the body, adjacent to the 2073A Spring and capture the hooked end of the spring with the front part of the catch ledge on the bottom of the 2073. Slide the 388B Bolt through the 2073 Latch and 2073B Bushing until the end of the 388B Bolt is flush with the right side of the 2073B Bushing.
5. Place the 373B Spacer on the right side of the 2073 Latch Lock, aligning its hole with the 388B Bolt on the left and with the catch ledge of 2073 Latch Lock still catching the hooked end of the Spring, push the Bolt into the 373B Spacer. Align the 373B Spacer with the body hole on the right side and push the 388B Bolt out the right side of the coupling body.
6. Closely examine the left side's interior body sidewall, adjacent to the 2073A Spring, and locate the catch ledge running at a 45 degree angle. This is where the straight leg of the spring needs to be placed. Using a flat bladed screw driver, pry the straight leg away from the top interior ledge of the coupling and rotate it until it engages with the catch ledge (See Image #3). Please note: Do not over stress the 2073A Spring when engaging either end.
7. Rotate the 2073 Latch Lock backwards, to the opened position. If spring is installed correctly, smooth increasing spring resistance should be felt when rotated. If no resistance or binding is felt, the spring and/or parts are not installed correctly.
8. Secure the 388B Bolt with 375A Locknut on the right side.
9. Insert the 2071 Bolt from the left side into the coupling body until the threaded end is approximately 1/8" past the left side interior body sidewall. Place the 2072A Spring onto the protruding 2071 Bolt's threaded end. The hook end of the spring should be pointing toward you and the straight leg facing downward, captured by the top interior ledge of the coupling (see Image #3).
10. Place the 2072B Bushing into the hole in the 2072 Latch. With one hand rotate the 2073 Latch Lock back to the opened position and hold. With the other free hand grasp the 2072 Latch and lower into position, catching the hooked end of the spring on the left side sidewall of the 2072 Latch. Once in position, gently allow the 2073 Latch Lock to rotate forward, into the closed position. Now align the 2072 Latch hole with the 2071 Bolt and slide the bolt to the right until fully seated. Due to the snug fit caused by the bushing, it is possible that while pushing the bolt into place, you may have to twist the bolt and wiggle the latch to get everything to line up properly. **Do not hammer or tap the bolt through. This action could damage the bushing.** Secure the bolt with the 297 Locknut on the right side.
11. Rotate the 2073 Latch Lock to the opened position and hold. Rotate the 2072 Latch to the opened position. If the spring is installed correctly, smooth increasing spring resistance should be felt when rotated. If no resistance or binding is felt, the spring and/or parts are not installed correctly. Reassemble correctly.
12. Once the coupling is assembled it should be opened and closed several times, testing for smooth and correct operation. **DO NOT** use the coupling if it does not operate properly. Call for assistance.
13. For the procedures mounting the assembled coupling back to its mounting structure, reference the corresponding installation guide.



IMAGE REFERENCE SECTION

Image 1

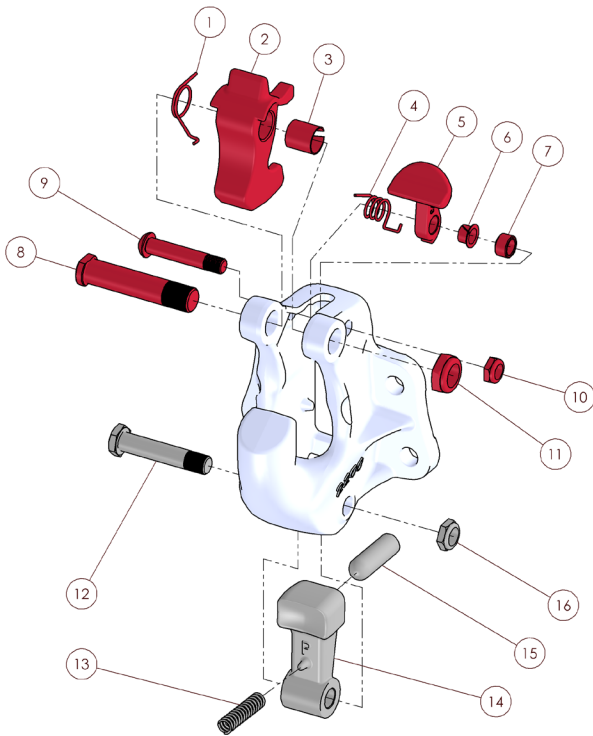

Item	Model #	Part #	Description
1	*2072A	10000224	Spring
2	*2072	10000223	Latch
3	*2072B	10000225	Bushing
4	*2073A	10000233	Spring
5	*2073	10000232	Latch Lock
6	*2073B	10000234	Bushing
7	*373B	10000341	Spacer
8	*2071	10000221	Bolt
9	*388B	10006295	Bolt
10	*375A	10000347	Locknut
11	*297	10000323	Locknut

Item	Model #	Part #	Description
12***	**274	10000308	Bolt
13	**266	10000290	Spring
14	**279	10000312	Shoe
15	**271	10000107	Thimble
16	**274A	10000309	Locknut

* Included in 2000PK (10000737)

** Included in 279PK (10000315)

*** For 2880 coupling ONLY - Use 374 Bolt (10000345), available individually.

Image 2

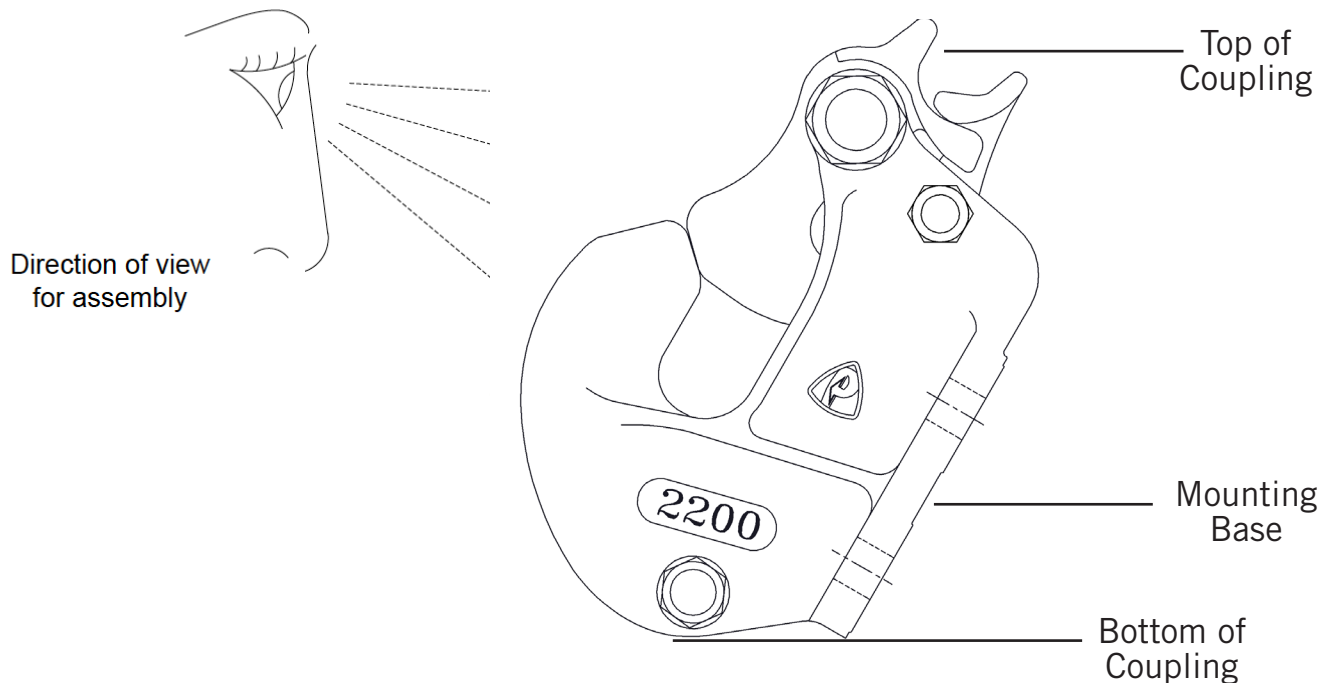

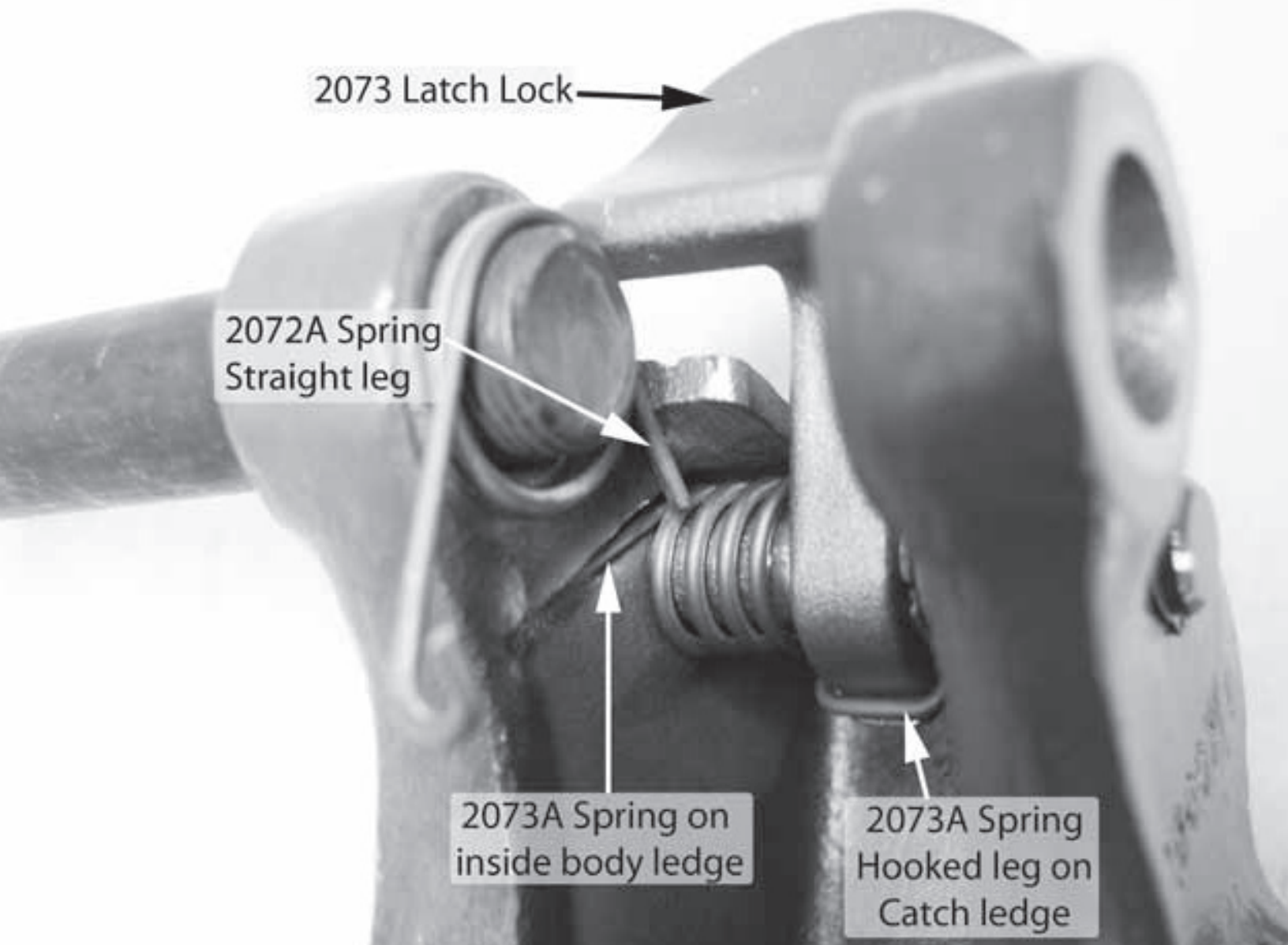

IMPORTANT GUIDELINES that apply to all Premier Air Adjusted Couplings

- Do not weld on any coupling assembly
- Always use Grade-8 fasteners properly torqued
- Do not apply lubricants to the coupling hook
- Air service chamber must be Type-24 or Type-30 with 90-120 PSI air supply
- Clean & inspect coupling for damage & excessive wear prior to each and every use
- Lubricate all coupling components at a minimum of 90 day intervals
- Do not bind-up (Jackknife) any application as stresses can cause damage to products or components, resulting in failure and detachment of the trailer while in use

ATTENTION!

End Users must read and follow this information.

DISTRIBUTORS & OEM'S: Please ensure that your customers are made aware of the following information on this page.

1. VERIFY THAT BOTH COUPLING'S AND DRAWBAR EYE'S RATED CAPACITIES MEET YOUR APPLICATION(S) REQUIREMENTS.
2. DO NOT OVERLOAD COUPLING OR DRAWBAR EYE.
3. INSPECT COUPLING, LATCH AND DRAWBAR EYE FOR CRACKS, BENDING DAMAGE OR EXCESSIVE WEAR.
DO NOT USE IF ANY OF THESE CONDITIONS EXIST!
4. CHECK FOR GAP BETWEEN CLOSED LATCH AND TOP OF HORN OR COUPLING BALL.
DO NOT USE IF GAP IS 3/8 IN. OR MORE.
5. MAKE SURE COUPLING IS LATCHED AND THAT LATCH WILL NOT OPEN.
6. PRIOR TO USE, ALWAYS CONNECT SAFETY CHAINS OF ADEQUATE STRENGTH FOR LOAD(S) BEING TOWED.
7. DO NOT BIND-UP (JACKKNIFE) ANY APPLICATION AS STRESSES CAN CAUSE DAMAGE TO THE COUPLING, DRAWBAR EYE, OTHER COMPONENTS OR ANY COMBINATION OF THEM. JACKKNIFING MAY RESULT IN FAILURE OF PRODUCTS OR COMPONENTS, RESULTING IN DETACHMENT OF THE TRAILER WHILE IN USE.
8. DO NOT APPLY LUBRICANTS TO THE COUPLING HOOK OR DRAWBAR EYE LOOP, AS THEY CAN COVER UP POSSIBLE DAMAGE AND ACCELERATE WEAR.
9. ALWAYS ABIDE BY ALL APPLICABLE STATE AND FEDERAL REGULATIONS GOVERNING SAFE AND PROPER TRANSPORTATION.
10. NEVER STRIKE ANY OF THESE COMPONENTS WITH A HAMMER OR ANY OTHER DEVICE.
11. ALWAYS VERIFY PROPER OPERATION OF LATCHING SYSTEM AND COUPLING COMPONENTS PRIOR TO DRIVE OFF.
12. NEVER USE A COUPLING THAT YOU DO NOT FULLY UNDERSTAND HOW TO PROPERLY OPERATE AND VERIFY SECURE LATCHING OF.
13. **NEVER REPLACE ANY PART IN ANY OF PREMIER'S ASSEMBLIES WITH NON-PREMIER COMPONENTS. DOING SO WILL VOID ALL WARRANTY AND POTENTIALLY COMPROMISE THE UNIT'S INTEGRITY, WHICH COULD RESULT IN PROPERTY DAMAGE, SERIOUS INJURY, OR DEATH.**



WARNING!

This envelope contains important instructions

AND MUST REMAIN ATTACHED TO THIS

PRODUCT. It may be removed only by the End User or by an Original Equipment Manufacturer who preserves this envelope and instructions and provides it to the end user.



PREMIER MANUFACTURING
THE FIRST NAME IN QUALITY COUPLINGS
800-255-5387 (503)234-9202
www.premier-mfg.com

Model 2000PK
Service Guidelines
Revised: 05/2023

WARRANTY: We warrant all Premier products to be free from defects in material or workmanship for one year. We will repair or replace, at our option, any Premier product which our examination reveals to be defective, provided that the product is returned to our factory, at Tualatin, Oregon transportation prepaid, within one year of purchase by the first retail purchaser. Our warranty does not extend to products which have been subject to misuse, neglect, improper installation, maintenance or application, nor does our warranty extend to products which have been repaired or altered outside of 3UHPLHU-V facility unless the repair or alteration has been expressly authorized in writing by Premier. **This warranty is in lieu of all other warranties, express or implied, and excludes warranties of merchantability, fitness for a particular purpose and otherwise, and in no event will Premier be liable for incidental, special, contingent or consequential damages.**

DISCLAIMER: Although great care has been taken to ensure accurate information throughout this document, Premier Manufacturing must reserve the right to alter any information contained within. These changes include but are not limited to: Dimensional changes, load capacity and availability of any part or assembly.

© 2009 Premier Manufacturing

All rights reserved. Any reproduction of the photographic images or any other portion of this document, including but not limited to the photocopying, or retention and/or storage in a retrieval system of any kind, is strictly prohibited without prior express written permission from Premier Manufacturing.

